



COCHIN PORT AUTHORITY  
MARINE DEPARTMENT  
E- TENDER No. MD/PMW/ GHDNS GRAB REPAIRS/2025-26

**Tender Document**

“Rate Contract for Repairs of Grabs of CoPA’s Grab Hopper Dredger Nehru Shatabdi for Two Years”

Tender publication date : 29-11-2024

Down loading of Tender Document : From 30-11-2024, 1700 hours  
to 23-12-2024, 1400 hrs

Last date and time for Submission of Tenders: : 23-12-2024, 15.00 hrs.  
Time and date of technical bid opening : 23-12-2024, after 15.30 hrs.

Opening Of The Price Bid : Will be informed later

Cost of Tender Document / Processing Fee : Rs.3,540/- (non refundable)  
(Tender fee is inclusive of 18% GST)

EMD : Rs.62180/-

E-Tendering portal : [www.Tenderwizard.com/CPT](http://www.Tenderwizard.com/CPT)

Office of the Deputy Conservator  
Cochin Port Authority,

Cochin – 682 009.  
Phone: 91 484 2666417, 2582500,2582521,2582377  
Fax: 91 484 2666417  
e-mail: [dc@cochinport.gov.in](mailto:dc@cochinport.gov.in)

**COCHIN PORT AUTHORITY**  
**MARINE DEPARTMENT**

Tender No.MD/PMW/ GHDNS GRAB REPAIRS/2025-26

**Tender for the “Rate Contract for Repairs of Grabs of CoPA’s Grab Hopper Dredger  
Nehru Shatabdifor Two years”**

**CONTENTS**

<b>SECTIONS</b>		<b>DESCRIPTION</b>	<b>PAGE NO.</b>
Section - I.	1	Notice Inviting Tender	3
	2	Instructions to Bidders	09
	3	Schedule-I - List of documents to be submitted by the tenderer	23
	4	Annexures (1 to14)	25
Section - II	1	General Conditions of Contract: Parts A - G	46
Section III	1	Special Conditions of Contract	83
Section - IV	1	Scope of Work, Technical Specifications & Drawings	90
Section V	1	Bill of Quantities	106



**Office of the Deputy Conservator,  
Cochin Port Authority,  
W/Island, Cochin, 682009, KERALA  
Tele: 91-0484-2666417/0484-2582500  
website: [www.cochinport.gov.in](http://www.cochinport.gov.in)**

Tender No.MD/PMW/ GHDNS GRAB REPAIRS/2025-26

date:29-11-2024

## SECTION – I

### 1. NOTICE INVITING TENDER

**1.1. Electronic Tenders (e-tenders)** in Single Stage Two Cover bidding procedure [Technical Bid and Financial Bid], are invited by the Deputy Conservator, Cochin Port Authority, Willingdon Island, Cochin-682 009 from reputed firms meeting the Minimum Eligibility Criteria specified below for **“Rate Contract for Repairs of Grabs of CoPA’s Grab Hopper Dredger Nehru Shatabdi for Two years”**

**1.2. Minimum Eligibility Criteria:** Tenderer must fulfill the following Minimum Eligibility Criteria to prove the techno-commercial competence and submit the documents in support thereof:

- (i) **Average Annual financial turnover** of the tenderer during the last three Financial Years, ending 31<sup>st</sup> March 2023 (ie. 2020-21, 2021-22 and 2022-23) should be atleast Rs.9,32,700/-.
- (ii) **Experience:** The tenderer should have successfully completed similar **works** during the last seven years ending **31.10.2024**, should be either of the following:
  - a) Three similar completed works costing not less than Rs.12,43,600/- OR
  - b) Two similar completed works costing not less than Rs.15,54,500/- OR
  - c) One similar completed work costing not less than Rs.24,87,200/-.

Note: In order to evaluate the tender, the value of executed works shall be brought to the current costing level by enhancing the actual value of the work upon completion, by using the following enhancement factors.

**Table 1.1**

Works executed Year before	Multiplying factor
One year [October, 2023]	1.07
Two years [October, 2022]	1.14
Three years [October, 2021]	1.21
Four years [October, 2020]	1.28
Five years [October, 2019]	1.35
Six years [October, 2018]	1.42

### Definition of Similar Works

Steel Fabrication/ repair/ welding works/ reconditioning of machinery/equipments in floating crafts/shipyards/ports/ power plants/petrochemical industries/process industries or any other reputed industries.

The bidders who have successfully completed at least one year of ongoing rate contracts for *similar works* as on 31-10-2024 and the value of the completed portion of the rate contract is meeting the criteria specified under clause 1.2(ii) above shall also be considered based on documentary proof issued by the clients.

**(iii) Technical Capability:** Tenderer should have a repair yard (either owned/leased) located **within 25 Kms from** Willindon Island , Kerala, where the repairs of Grabs are proposed to be carried out in case the contract is awarded.

### **List of documents to be furnished along with the tender to prove the Minimum Eligibility Criteria:-**

- (i) A statement duly certified by the Chartered Accountant (his Registration Number should be shown) showing the Annual Financial Turnover during the last three financial years ending 31-03-2023 (viz.2020-21, 2021-22 and 2022-23)) should be furnished as per Annexure-4 along with copies of the audited Annual Balance sheet including Profit & Loss Account Statements for the above period.
- (ii) Copy of Registration certificate of the Tenderer. (In case, the tenderers repair yard is leased, copy of lease agreement shall also be furnished along with the tender.)
- (iii) Notarized copies of Work Orders and Satisfactory Completion Certificate issued by the Client in support of contracts having been executed as proof. Details of such contracts shall be furnished as per Annexure-3. The experience certificate of Works executed in private sectors / organizations shall be considered for qualification, only on submission of Form 26AS as per TRACES Site along with Work order and completion certificate. **If the experience certificate is issued by CoPA, notarization is not required( only copies shall submit)**

### **1.3. Other Eligibility Considerations**

1.3.1. Even though the Bidders meet the above qualifying criteria, they are subject to be disqualified if they have:

- i) Made misleading or false representations in the forms, statements and attachments submitted in proof of the eligibility requirements; and/or
- ii) Record of poor performance such as abandoning the works, not properly completing the contract, inordinate delays in completion, litigation history, barred by the Central / State Government or organizations under them, from participating in any project or financial failures etc.

1.3.2. The Bidder should have valid GST Registration Certificate and PAN. Copies of supporting documents to be attached.

1.3.3. The Bidder should not have been blacklisted /debarred by any Govt. of India Organizations / PSU/ PSE / Govt. Depts. etc. for breach of any applicable laws or violation of regulations or breach of contractual agreement or rendering unsatisfactory

services during the last 3 (Three) years. (Self-declaration to be submitted by the bidder along with their bid as per Annexure -8).

**1.3.4. The Bidders should have EPF and ESI registration**

**1.4. Pertinent information to the tender is given in the following Tables:**

(i) Schedule of different activities till submission of the bids:

**Table 1.2**

Sl. No.	Particulars	Date and Time
1	Tender e-publication date	29-11-2024
2	Download period of Bid Documents	30-11-2024 to 23-12-2024 up to 14:00 hrs.
3	Pre-Bid meeting	10-12-2024 at 11.00 hrs. (Through VC) Google Meet joining info Google Meet link: <a href="https://meet.google.com/nix-vvex-yex">https://meet.google.com/nix-vvex-yex</a>
4	Last date for seeking clarifications	Up to 17:00 hrs. on 09-12-2024
5	Last date and time of submission of Bid	23-12-2024 up to 15.00 hrs.
6	Date and time of opening the Technical Bid	23-12-2024 after 15.30 hrs.
7	Date and time of opening of Financial Bids of technically qualified bidders	Will be announced after completion of technical evaluation and pre-qualification of bids.

(ii) General Information:

**Table 1.3**

Sl. No.	Item	Details
1	Name of the work to be carried out	“Rate Contract for Repairs of Grabs of CoPA’s Grab Hopper Dredger Nehru Shatabdi for Two years”
2	Employer	Cochin Port Authority
3	Employer’s Representative	Deputy Conservator
4	Executing Authority	Deputy Conservator, Cochin Port Authority

**1.5. Bid information :**

**Table 1.4**

i)	Estimated Amount put to Tender	<b>Rs.31,09,000/- (Rupees Thirty One lakh Nine Thousand only) excluding GST</b>
ii)	Earnest Money Deposit	Rs.62,180/- (Rupees sixty two Thousand One Hundred and Eighty only) Banker’s Cheque or Demand Draft issued by Nationalized/ Scheduled banks, en-cashable at Cochin, drawn in favour of F.A. & C.A.O, Cochin Port

		Authority or Online payment through RTGS to the below mentioned bank account of Cochin Port Authority. <b>BANK DETAILS:-</b> Name of the Bank: State Bank of India Name of the Branch: Cochin Port Authority Branch Beneficiary : Cochin Port Authority Account No.: <b>10601197375</b> IFSC Code:SBIN0006367
iii)	Cost of Bid document	Rs.3,540/-(3000+18% GST) (Non- refundable) furnished either through Demand Draft /Pay order/ Banker's Cheque drawn in favour of the FA & CAO, Cochin Port Authority, payable at Kochi, from any Commercial Bank in India or payment online, being the cost of single copy of the tender document.
iv)	Validity period of Tender	90 days from the Last Date for Receipt of Tenders.
v)	Completion Period of Contract	Two years from the date of LoA/Work Order
vi)	Name , Designation, Address and other details (For Submission of Bid in response to NIT)	Capt. T M Kumar Deputy Conservator Cochin Port Authority, Willingdon Island, Kochi, 682009, Kerala. Email: dc@cochinport.gov.in

- 1.6.** Bid Document can be downloaded from the e-Tendering portal [www.tenderwizard.com/CPT](http://www.tenderwizard.com/CPT) on the dates specified above by making online requisition. Bid Document will also be available in Cochin Port website ([www.cochinport.gov.in](http://www.cochinport.gov.in)) as well as Central Public Procurement Portal (CPP Portal) [www.eprocure.gov.in/cppp](http://www.eprocure.gov.in/cppp) , which can be downloaded for submission. The cost of Bid Document shall be furnished in the form of Demand Draft/ Pay Order/ Banker's Cheque drawn in favour of FA & CAO, CoPA, along with the submission of Bid. Bidders are also permitted to pay the cost of Bid Document by online mode (NEFT/RTGS). Bank Account details of Cochin Port Authority is furnished in the below Table. The Bidders shall upload the proof of payment made towards cost of Bid Document along with the Bid Document while submitting the Bid electronically in the e-Tendering Portal.
- 1.7.** In case of online payment of Cost of Tender Document / EMD, UTR number of the transaction should be communicated to the Deputy Conservator's e-mail of Cochin Port Authority as mentioned in Table 1.4 above, well in advance before opening of e-tender. Cochin Port Authority will verify the receipt of Cost of Tender Document /EMD as referred in UTR number in the Bank Account Number mentioned below. If cost of tender document/EMD has not been reflected in the Bank Account of Cochin Port Authority, the bid will be rejected. Bank Details of Cochin Port Authority are given below:

**Table 1.5**

Name of Bank	State Bank of India
Name of Branch	Cochin Port Authority
IFSC Code	SBIN0006367
Account No	10601197375
Account Holder's Name	Cochin Port Authority

- 1.8. The bidders need to obtain the one time User ID & password for log-in to e-Tendering system from the service provider M/s. KEONICS by paying the registration amount of Rs. 1180/- by online payment using Credit/Debit Card/Net Banking or DD in favour of “KSEDCL, Bangalore”.
- 1.9. The intending bidder must have valid Class II or Class III digital signature certificate to submit the bid. For further details and to obtain the digital signature, please contact e-Tender Help Desk No. 080-49352000 / 9605557738.
- 1.10. The bidder is responsible to download the Tender Document, all Addenda / Amendments / Errata / Replies to the queries of bidders etc., if any, issued by CoPA, from the e-Tendering Portal / Cochin Port Website / CPP Portal before submission of the bid. Any shortfall in submission of the said Tender Document/Addenda / Amendments / Errata / Replies to the queries of the tenderer etc. duly signed along with the downloaded documents while uploading the bid, will render the Bid incomplete and incomplete Bid documents may be rejected.
- 1.11. All bids shall be submitted online only, on the website [www.tenderwizard.com/CPT](http://www.tenderwizard.com/CPT), strictly in accordance with the Instructions to Tenderers and Terms and Conditions given in the tender document. No bids shall be accepted off-line (Hard copy).
- 1.12. Cochin Port Authority will not be held responsible for any technical snag or network failure during online bidding. It is the bidder’s responsibility to comply with the system requirement, i.e. hardware, software and internet connectivity, at bidder’s premises to access the e-Tender portal. Under any circumstances, Cochin Port Authority shall not be liable to the bidders for any direct/indirect loss or damages incurred by them, arising out of incorrect use of the e-Tender system or internet connectivity failures.
- 1.13. The Bidder shall submit Originals of: (i) DD /Pay Order/ Banker’s Cheque towards the Cost of Bid Document; (ii) EMD (iii) Power of Attorney in favour of signatory(s) to the Bid; 1(v) Copy of documentary proof of MSME/NSIC registration (if applicable) along with letter of submission in a sealed cover superscribing thereon the Tender Number, Name of Work, date notified for submission of tender and the name and address of the tenderer, to the Deputy Conservator, Cochin Port Authority, W/Island, Cochin – 682009, KERALA, on or before the last date and time of submission of bids. Non submission of original financial instrument towards cost of Bid Document, EMD, Power of Attorney as stated above before opening date and time of the Bid, will make the tender liable for rejection.
- 1.14. The Contractor’s Scope of Work of Tender for “Rate Contract for Repairs of Grabs of CoPA’s Grab Hopper Dredger Nehru Shatabdi for Two years” consists of maintenance/repairs of grabs of Cochin Port Authority’s Dredger, ‘GHD Nehru Shatabdi’. Works detailed in the price schedule I&II (BOQ) comprises of various works connected with repair / reconditioning of grabs including to and fro transportation of Grabs. It is not necessary that all the works listed in the schedule of work are to be carried out on all grabs taken up for repairs. The repair/renewal works of each grabs shall be done **at contractor’s repair yard**. After receiving verbal/mail) work order from CoPA for each grab, the contractor shall transport the grab to his repair yard for repairs and bring back to CoPA premises after repairs by contractor’s vehicle and his own risk and unload it to the berths as per EIC’s instruction. After dismantling the defective grab by the contractor at his site, Engineer-in-charge of the vessel GHDNS or representative of MES will survey and list out details of work. Based on this, individual work order will be placed for each grab, line item wise, as per the price schedule. The contractor has to carry out all necessary repairs, including handling and transporting of grabs or its components from the CoPA berths to the contractor’s workshop and back, at his own and risk. CoPA will provide cranes/lifting

equipments free of cost for loading/unloading the grab/ its components into/from the contractors' vehicle only at CoPA at premises. Any minor work which is required to be carried out during commissioning/operation of grabs will be permitted to undertake in CoPA premises.

- 1.15.** The details given in the Scope of Work, Drawing, and Special Conditions of Contract etc. are indicative and the Bidders have to assess the exact work requirement through their own means and sources and accordingly, costing shall be done for the work. It is made clear that the above said statement regarding indicative details of works to be executed does not attract any liability on the Port and the Port cannot be held responsible with any liability on the strength of the said statement.
- 1.16.** All Tenderers are advised to visit CoPA and inspect the Grabs before submitting their offer in order to make themselves fully aware of the nature of work. They shall also study the scope/nature of work before quoting. Any doubt regarding the specifications, scope or any other conditions, shall be discussed with the Engineer in charge of GHDNS/ MES /SE (M) TT, CoPA. Cochin Port will not be responsible for any cost or expenses incurred by the Tenderer in connection with the preparation or delivery of the tenders including cost and expenses related to visits to the sites. The intending bidders are requested to take prior permission of Cochin Port along with the details of officials visiting the vessel by communicating to the e-mail given below. The visit for inspection shall be made on any working day, after obtaining the prior confirmation of Cochin Port Officials (Sri. Thomas Mathew, MES, Mobile No. 9447290256, email- [mes@cochinport.gov.in](mailto:mes@cochinport.gov.in), Sri Peter Thomas, CE,GHDNS , Mob. 9995043407).
- 1.17.** Exemption from the payment of Cost of Tender document and EMD shall be given to Micro and Small Enterprises (MSEs) as defined in MSE Procurement Policy issued by Department of Micro, Small and Medium Enterprises (MSME) or are registered with the NSIC or the concerned Ministry or Department as provided in GFR 2017. They are required to submit documentary proof of such registration along with the original documents as specified in Clause 1.13 above, for claiming the available exemptions and a scanned copy of Exemption Certificate shall be uploaded in the e – Tender Portal.
- 1.18.** The bidder should not have been blacklisted or debarred by any Central / State Government / Agency of Central / State Government / Public Sector Undertaking / Regulatory Authority of India at the time of submission of this bid.
- 1.19.** The undersigned reserves the right to reject/cancel/postpone/amend/ annul any one or all Bids at any stage of the Bid, which shall be binding on all Bidders without any liability or any obligation for such acceptance, rejection or annulment, without assigning any reasons.
- 1.20.** This tender notice shall form part of the tender document and are to be signed and uploaded along with the technical bid.

**DEPUTY CONSERVATOR**  
Cochin Port Authority  
Willingdon Island,  
Cochin-682009, Kerala  
Email:dc@cochinport.gov.in  
[www.cochinport.gov.in](http://www.cochinport.gov.in)

## **2. INSTRUCTIONS TO TENDERER**

### **1. Introduction**

- 1.1. Sealed tenders in two-cover system are invited from eligible tenderers for “Rate Contract for Repairs of Grabs of CoPA’s Grab Hopper Dredger Nehru Shatabdi for Two Years” as per the Scope of Work and Technical Specification given in Section IV of this tender document.

### **2. General Instructions**

- 2.1. The Contract is to be executed as described in the Bid document and in particular in the Scope of Work and Technical Specification, General Conditions of Contract, Special Conditions of Contract, Bill of Quantities etc.
- 2.2. Before submitting the bid, the bidder shall examine carefully all conditions of contract, specifications, etc. supplied herewith. It will be deemed that prior to the submission of tender, the tenderer has inspected the Grabs and has satisfied himself as to the nature of work, general conditions, working conditions etc. and that the tenderer has estimated his cost accordingly and the Port Authority will be in no way responsible for the lack of such knowledge and also consequences thereof to the tenderer. Failure to visit the Grabs kept at CoPA premises will in no way relieve the successful Bidder of any of the obligations in performing the Work in accordance with this Bid Document including addenda/corrigenda, within the quoted price.
- 2.3. A bidder shall be deemed to have full knowledge of all documents, working conditions etc. whether he has inspected them or not. The submission of a bid by the bidder implies that he has read the Notice and Conditions of Contract and has made himself aware of the scope and specifications and other factors bearing on the bid and that they are binding on him.
- 2.4. The bidders may please note that the EMPLOYER will not entertain any correspondence or query on the status of the offers received against this Bid. Bidders are also requested not to depute any of their personnel or agents to visit the Employer’s offices for making such enquiries till finalization of the bid. Should the EMPLOYER find it necessary to seek any clarification, technical or otherwise, the concerned bidder will be duly contacted by the EMPLOYER.
- 2.5. Canvassing in any form by the bidder or by any other agency acting on behalf of the bidder after submission of the bid may disqualify the said bidder. The Employer’s decision in this regard shall be final and binding on the bidder.
- 2.6. The EMPLOYER will not be liable for any financial obligation in connection with the work tendered until such time the EMPLOYER has communicated to the successful bidder in writing its decision to entrust the Contract (covered by the bid document issued to him).
- 2.7. Telex / E-mail offers will not be considered. Bidders should prepare their bid themselves and submit it **online only**. Bids submitted by agents will not be recognized.
- 2.8. Bids received after the due date and time and any change in bid after the specified date will be rejected. EMPLOYER will not be responsible for the loss of the bid document or for the delay in postal transit.
- 2.9. In case of an unscheduled holiday to CoPA on the prescribed closing / opening day of the bid, the next working day will be treated as the scheduled prescribed day of closing / opening of the bid.
- 2.10. While evaluating the bids received, regard would be paid to National Defense and Security Considerations, at the discretion of the Cochin Port. Bid received from any bidder may be summarily rejected on National Security Consideration without any intimation thereof to the bidder.
- 2.11. If there are varying or conflicting provisions made in any document forming part of the contract, the Deputy Conservator, Cochin Port Authority, Cochin – 682009 shall be the deciding authority with regard to the intention of the document which will be binding on the

Bidder.

- 2.12. In case Cochin Port desires to inspect the tenderer's Yard for confirmation of its availability and capacity etc., necessary arrangements shall be made by the tenderer for such inspection.
- 2.13. Any error in description, any omissions there from shall not vitiate the contract or release the Contractors from the execution of whole Work or any part of the Works comprised therein, according to the Scope of work, Specifications or from any of his obligations under the contract.
- 2.14. The Contractor shall comply with all the provisions of the Indian Employees Compensations Act, Provident Fund Regulations, Employees Provident Fund Act, ESI Act, the Minimum wages Act and other applicable labor laws etc. amended from time to time and rules framed there under and other laws affecting the contract labour that may be brought in to force from time to time.
- 2.15. The Contractor shall be registered under GST and shall furnish documentary evidence in support of valid GST registration.
- 2.16. Exemption from the payment of Cost of Tender document and EMD shall be given to Micro and Small Enterprises (MSEs) as defined in MSE Procurement Policy issued by Department of Micro, Small and Medium Enterprises (MSME) or are registered with the NSIC or the concerned Ministry or Department as provided in GFR 2017. They are required to submit documentary proof of such registration along with the original documents as specified in Clause 1.13 above, for claiming the available exemptions and a scanned copy of Exemption Certificate shall be uploaded in the e – Tender Portal. **The MSEs are exempted from the payment of Cost of Tender document and EMD.**
- 2.17. In the Letter of Submission, the Bidder shall compulsorily indicate two nos. of current active email addresses to which further Bid related communication can be sent by CoPA. All communication from CoPA shall be deemed to have been delivered when the email is sent to the specified email addresses, ie, the date of sending email by CoPA shall be considered as the date of receipt by the Bidder. CoPA shall, in no way, be responsible for the non-receipt of any such communication by the Bidder due to whatever reasons on this account.
- 2.18. In all matters arising out of the provisions of this tender/contract, the laws of the Union of India shall be the governing laws and courts in Ernakulam, Kerala State shall have exclusive jurisdiction.

### 3. **Invitation for Bids:**

- 3.1. The Invitation for Bids is open to all eligible bidders meeting the Minimum Eligibility Criteria.

### 4. **Downloading of Tender Documents:**

- 4.1. Tender documents can be downloaded from the e-Tendering portal [www.tenderwizard.com/CPT](http://www.tenderwizard.com/CPT) on the dates specified in NIT by making online requisition. Tender document can also be downloaded from Cochin Port website [www.cochinport.gov.in](http://www.cochinport.gov.in) or Central Public Procurement (CPP) Portal. Demand Draft /Pay Order/ Banker's Cheque for cost of tender document drawn in favour of the Financial Adviser & Chief Accounts Officer (FA &CAO), CoPA from any Commercial Bank having its branch at Kochi shall be submitted at the time of submission of bids and scanned copy of the same shall be attached with the e-tender. In case if the payment in this regard is made on-line, proof of same shall be furnished to the Deputy Conservator by email prior to the opening of Technical Bids.
- 4.2. In case of tender document being downloaded from the website, at the time of uploading, the tenderer shall give an undertaking that no changes have been made in the document. The Port's Tender document will be treated as authentic tender and if any discrepancy is noticed at any stage between the Port's tender document and the one submitted by the tenderer, the Port's document shall prevail. For the discrepancies found at any time, the tenderer shall be

liable for legal action.

5. **One Bid per Bidder:** Each Bidder shall submit only one Bid. A Bidder who submits or participates in more than one Bid will cause all the proposals with the Bidder's participation to be disqualified.
6. **The Bidder:** The Bidder shall be a single entity only.
7. **Cost of Bidding:** The Bidder shall bear all costs associated with the preparation and submission of his Bid, and the Employer will in no case be responsible and liable for those costs.

8. **Visiting the CoPA for inspecting Grabs:**

- 8.1. The Bidder, at the Bidder's own responsibility and risk is encouraged to visit CoPA to inspect Grabs and obtain all information that may be necessary for preparing the Bid and entering into a contract for execution of the Work. The costs of visiting CoPA shall be borne by the Bidder. For the above purpose, the tenderer may contact the Chief Engineer of the vessel/SME,MES, CoPA.

9. **Clarification of the Bidding Documents:**

- 9.1. The tenderers are advised to examine the Tender Document carefully and if there be or appear to be any ambiguity or discrepancy in the documents, or any clarifications needed on the Tender Documents; these shall be referred to the Deputy Conservator in writing at the following address, so as to reach them at least by **09-12-2024 at 17:00 hrs. It is to be noted that no queries, clarifications will be answered after this date.**

Address: Deputy Conservator, Cochin Port Authority, Willingdon Island, Cochin,  
682009, Kerala, India.

Phone: 91-0484-2666417 / 2582500/ 2582511/2582521

Fax: 91-0484-2666417

Email: [dc@cochinport.gov.in](mailto:dc@cochinport.gov.in); [sajeev.va@cochinport.gov.in](mailto:sajeev.va@cochinport.gov.in); [noby@cochinport.gov.in](mailto:noby@cochinport.gov.in)

10. **Pre-Bid Meeting:**

A prospective tenderer requiring any clarification of the tender shall submit their queries in writing / e-mail in advance before 17.00 hrs. on 09-12-2024. The Pre-Bid meeting will be held through Video Conference at 11.00 hrs. on 10-12-2024. The link for attending the meeting through Video Conference is as follows:

**Google Meet joining link:** <https://meet.google.com/nix-vvex-yex>

11. **Amendment of Bidding Documents:**

11.1. The Deputy Conservator, Cochin Port Authority shall have the right to omit or suspend certain items of Work or revise or amend the Bid documents prior to the due date of submission of the Bid by issuance of addenda/corrigenda. Any addendum / corrigendum thus issued shall be part of the Tender Document. The addendum/corrigendum, if any, shall only be hosted in the e-tender portal as well as in the website of the Cochin Port. It is the responsibility of the Bidders to download such addenda/ corrigenda hosted in the website and submits the same duly signed along with the Bid. In order to afford the Bidders with reasonable time to take addendum into account, or for any other reason, the Port may, at its discretion, extend the due date for submission of Bid and Bid Extension Notice shall be hosted in the web site.

12. **Preparation of bids:**

- 12.1. All documents relating to the bid shall be in the English language.

13. **Minimum Eligibility Criteria:** Tenderer must fulfill the following Minimum Eligibility Criteria to prove the techno-commercial competence and submit the documents in support thereof:

(i) **Average Annual financial turnover** of the tenderer during the last three Financial Years, ending 31<sup>st</sup> March 2023 (ie. 2020-21, 2021-22 and 2022-23) should be atleast Rs.9,32,700/-.

(iii)**Experience:** The tenderer should have successfully completed similar **works** during the last seven years ending **31.10.2024**, should be either of the following:

- d) Three similar completed works costing not less than Rs.12,43,600/- OR
- e) Two similar completed works costing not less than Rs.15,54,500/- OR
- f) One similar completed work costing not less than Rs.24,87,200/-.

Note: In order to evaluate the tender, the value of executed works shall be brought to the current costing level by enhancing the actual value of the work upon completion, by using the following enhancement factors.

**Table 1.1**

Works executed Year before	Multiplying factor
One year [October, 2023]	1.07
Two years [October, 2022]	1.14
Three years [October, 2021]	1.21
Four years [October, 2020]	1.28
Five years [October, 2019]	1.35
Six years [October, 2018]	1.42

**Definition of Similar Works**

Steel Fabrication/ repair/ welding works/ reconditioning of machinery/equipments in floating crafts/shipyards/ports/ power plants/petrochemical industries/process industries or any other reputed industries.

The bidders who have successfully completed at least one year of ongoing rate contracts for *similar works* as on 31-10-2024 and the value of the completed portion of the rate contract is meeting the criteria specified under clause 1.2(ii) above shall also be considered based on documentary proof issued by the clients.

(iii)**Technical Capability:** Tenderer should have a repair yard (either owned/leased) located **within 25 Kms from** Willindon Island , Kerala, where the repairs of Grabs are proposed to be carried out in case the contract is awarded.

**List of documents to be furnished along with the tender to prove the Minimum Eligibility Criteria:-**

- (i) A statement duly certified by the Chartered Accountant (his Registration Number should be shown) showing the Annual Financial Turnover during the last three financial years ending 31-03-2023 (viz. 2020-21, 2021-22 and 2022-23) should be furnished as per Annexure-6 along with copies of the audited Annual Balance sheet including Profit & Loss Account Statements for the above period.
- (ii) Copy of Registration certificate of the Tenderer. (In case, the tenderers repair yard is leased, copy of lease agreement shall also be furnished along with the tender.)
- (iii) Notarized copies of Work Orders and Satisfactory Completion Certificate issued by the Client in support of contracts having been executed as proof. Details of such contracts shall

be furnished as per Annexure-3. The experience certificate of Works executed in private sectors / organizations shall be considered for qualification, only on submission of Form 26AS as per TRACES Site along with Work order and completion certificate. **If the experience certificate is issued by CoPA, notarization is not required( only copies shall submit)**

#### 14. Other Eligibility Considerations

14.1. Even though the Bidders meet the above qualifying criteria, they are subject to be disqualified if they have:

- i) Made misleading or false representations in the forms, statements and attachments submitted in proof of the eligibility requirements; and/or
- ii) Record of poor performance such as abandoning the works, not properly completing the contract, inordinate delays in completion, litigation history, barred by the Central / State Government or organizations under them, from participating in any project or financial failures etc.

14.2. The Bidder should have valid GST Registration Certificate and PAN. Copies of supporting documents to be attached.

14.3. The Bidder should not have been blacklisted /debarred by any Govt. of India Organizations / PSU/ PSE / Govt. Depts. etc. for breach of any applicable laws or violation of regulations or breach of contractual agreement or rendering unsatisfactory services during the last 3 (Three) years. (Self-declaration to be submitted by the bidder along with their bid).

14.4. The bidders having *EPF and ESI registration only shall be considered for qualification* in the Bids, if applicable, as per EPF/ESI Acts. In case the bidder does not have the required number of employees which makes such registration mandatory, an under taking to this effect shall be furnished.

#### 15. Bid Price

15.1. The price schedule consists of Two parts viz, Price schedule - I& Price Schedule II. Price **schedule- I consists of 61 line items**. The bidders shall quote their rates for all the 61 line items in schedule-I **including cost of materials & labour and excluding GST**. No line items in the price bid should kept blank.

15.2. **Price schedule- II consist of 63 types of steel renewal works**. The bidder shall quote **per KG rate for the total anticipated quantity steel to be renewed** mentioned in the Price schedule- II **excluding GST**.

15.3. **All labour, materials and consumables required for repairs of the grab shall be in the scope of the contractor and cost of same also should be included in the quoted rate of each line item in the Price schedules.**

15.4. Equipments like **crane and Fork lift for loading and unloading** the grabs to and from the contractor's vehicle will be arranged by CoPA **only in Port premises on Port Account**.

15.5. The tenderer shall quote the rates against all the **61 line items in Schedule -I and Per Kg rate for the total anticipated quantity of steel renewal work in Schedule-II**. Otherwise, their tender will not be considered. This confirmation shall be indicated in the Schedule –I of the technical bid, otherwise their offer will be disqualified and price bids will not be opened.

15.6. The price shall be quoted by filling the prescribed format of price schedule **on- line only**. The rates quoted should be firm without any price variation clauses

#### 16. Bid Validity:

- 16.1. Bids shall remain valid for a period of not less than ninety days (90) after the deadline date for bid submission. A bid valid for a shorter period shall be rejected by the Employer as non-responsive. Should any tenderer withdraw or modify his Tender during the period of validity specified in the Bid Documents (including extended validity, if any) the bid submitted would be rejected and such bidders will be suspended from participating in the future tenders invited by Cochin Port Authority for a period of two years from the date of such Suspension Orders.
- 16.2. In exceptional circumstances, prior to expiry of the original time limit, the Employer may request the Bidder to extend the period of validity for an additional period. The request and bidders response shall be made in writing. A bidder agreeing to the request will not be permitted to modify his bid (i.e, the extension shall be unconditional).

**17. Bid Security / EMD:**

- 17.1. The tender shall be accompanied by Earnest Money Deposit amounting to the applicable value of EMD indicated below. The tender not accompanied with EMD will be treated as non responsive and will be rejected. The Earnest Money Deposit shall be submitted in the form of demand draft/banker's cheque drawn in favour of FA &CAO, Cochin Port Authority, Cochin from any Scheduled Bank or Nationalized Bank, having its branch in Cochin. The original DD/Banker's Cheque shall be submitted to the Deputy Conservator, Cochin Port Authority, Willingdon Island, Cochin –682 009 **upto 15:00 hrs. on 23-12-2024**. The Earnest Money Deposit will not carry any interest. Scanned copy of the DD/ Banker's Cheque shall be attached with the tender submitted "on line". In addition to the Demand Draft/Banker's Cheque, online payment through RTGS to the following Account of Cochin Port Authority is also acceptable

**BANK DETAILS:-**

Name of the Bank: State Bank of India

Name of the Branch: Cochin Port Authority Branch

Beneficiary : Cochin Port Authority

Account No.: **10601197375**

IFSC Code:SBIN0006367

- 17.2. The EMD shall be forfeited under following circumstances:
- a. In the event of the Tenderer withdrawing/modifying his tender before the expiry of tender validity of 90 days from the date of submission and opening.
  - b. Failing to enter into an agreement with Cochin Port Authority or failing to furnish performance guarantee upon award of contract as required in the tender within the stipulated time or within such extended time granted by Cochin Port Authority. In such cases the tender shall be liable to be cancelled and EMD shall be forfeited.
- 17.3. The Earnest Money Deposit of unsuccessful Tenderer shall be returned after award of contract to the successful Tenderer. The EMD of successful Tenderer will be refunded on submission of security deposit and executing the agreement as per tender clause.
- 17.4. Exemption from the payment of Cost of Tender document and EMD shall be given to Micro and Small Enterprises (MSEs) as defined in MSE Procurement Policy issued by Department of Micro, Small and Medium Enterprises (MSME) or are registered with the NSIC or the concerned Ministry or Department as provided in GFR 2017. They are required to submit documentary proof of such registration along with the original documents as specified in Clause 1.13 of NIT, for claiming the available exemptions and a scanned copy of Exemption Certificate shall be uploaded in the e – Tender Portal.
- 17.5. Cochin Port Authority reserves its right to suspend the bidders from participating in the future tenders invited by Cochin Port Authority for a period of two years from the date of such Suspension Orders, under the following circumstances:

- (i) If after the opening of Tender, if the bidder withdraw or modify his Tender during the period of validity specified in the Bid Documents (including extended validity, if any) or do not accept the correction of the Tender Price pursuant to any arithmetical errors.
- (ii) After the award of work, if the bidder fails to furnish the required Performance Security or fails to sign the Contract, within the time limits specified in the Tender Document.

**18. No Alternative Proposals by Bidders:**

- 18.1. Bidders shall submit offers that comply with the requirements of the Tender documents. Alternatives will not be considered.

**19. Format and Signing of Bid:**

- 19.1. Tenderer shall prepare one set of his Tender, duly completed and signed, along with other documents mentioned hereinafter. Form of Bid shall be signed by a person or persons duly authorized to sign on behalf of the Bidder with signature duly witnessed and company seal affixed. The Power of Attorney (in original) authorizing the signatory/s of the Tender shall be enclosed. All pages of the bid where entries or amendments have been made, shall be signed by the person or persons signing the Bid.
- 19.2. If the tenderer is an individual it shall be signed by the individual and his full name and address shall be given. A self-declaration to the effect that the bidder is the sole owner of the bidding firm shall be furnished. In the event of the tender being submitted by a registered partnership firm, it must be accompanied by a copy of Registered Partnership Deed. The tender in such case shall be signed by a person holding a proper Power-of-Attorney authorizing him to do so and to bind all the partners in all matters pertaining to the contract including the arbitration clause. Such power-of-attorney shall be duly executed on a stamp paper of appropriate value, in the name of Bidder's authorised representative to act on behalf of the Bidder, duly authenticated by a notary public or equivalent certifying authority to be attached with the tender which must disclose that the firm is duly registered under Indian Partnership Act. If the tender is made by a Limited Company it shall be signed by a duly authorized person. In such cases, Power of Attorney duly executed in stamp paper of appropriate value, in the name of Bidder's authorised representative to act on behalf of the Bidder, duly authenticated by a notary public or equivalent certifying authority shall be furnished along with the tender. In the case of a Limited Company the tender should be accompanied by the Memorandum and Articles of Association, copy of Board's Resolution showing the authority to sign the tenders by the signatory and notarized copy of the Incorporation Certificate of the Company.

**20. Bid Submission:**

- 20.1. Bid shall be submitted in two parts, **Part - I: Technical Bid** and **Part - II: Price Bid through e-tender mode** before the last date and time of submission of bid.
- 20.2. For online submission of Technical **Bid**, the scanned copies of the documents as detailed in clause 21.1 below need to be submitted through e-Tendering mode on [www.tenderwizard.com/CPT](http://www.tenderwizard.com/CPT).
- 20.3. Price Bid (Price Schedule-I&II) in the provided format shall be submitted only through e-tendering mode on [www.tenderwizard.com/CPT](http://www.tenderwizard.com/CPT). **In no case shall filled in Price Bid (Schedule I& II) (BOQ) be submitted in hard copy, as it shall result in rejection of the tender.**
- 20.4. Tenders shall be submitted "**online**" strictly in accordance with the Instructions to Bidders and Terms & Conditions given in the Tender Document. The Bidders should submit scanned copy of all the required documents such as DD / Pay Order / Banker's Cheque towards the cost of tender and EMD ; proof of experience, financial details etc. through the e-tendering portal.
- 20.5. **The Bidder shall submit the originals of (i) DD/ Pay Order/ Bankers Cheque towards the cost of Tender Document (ii) EMD (iii) Power of Attorney, if applicable, (iv)**

**Documentary proof of MSME/NSIC registration (if applicable) along with letter of submission in a sealed cover duly mentioning the Tender No. & Name of Work, due date of opening of Bid and Name of the Bidder to the Deputy Conservator, Cochin Port Authority, W/Island, Cochin – 682009, KERALA so as reach on or before the last date and time fixed for submission in the tender.**

20.6. Non submission of the original financial instrument towards cost of Tender Document, EMD within the above period leads to disqualification of Bids.

20.7. The successful Bidder shall submit original of complete Technical Bid already submitted in e-mode within 7 days of receipt of Letter of Acceptance issued for the Work.

## 21. Information Required in the Bid

21.1. **Part I -Technical Bid** shall contain the following:

- a) Cost of Tender Document
- b) Earnest Money Deposit
- c) Letter of Submission (vide *Annexure- 1*)
- d) Power of Attorney (in original) in favour of signatory/s to the Tender, duly authenticated by Notary Public. (vide *Annexure -2*)
- e) Check list as per **Schedule I**
- f) Organization Details (vide *Annexure-6*)
- g) Concurrent Commitments (**vide Annexure-7**).
- h) Details of past experience as per *Annexure-3* and Work Orders and Completion Certificates in proof of experience in Similar Works as detailed under clause 13 of Instruction to Bidders.

Explanatory Notes:

- (1) Original or notary certified copy of completion certificates of each Work issued by the owner/ the responsible officers of the owner under whom he has executed such contracts along with notarized copy of connected Work order shall be attached. The completion Certificate shall invariably contain the following among other things.
  - (i) Brief details of Work involved
  - (ii) Completion cost of the Work
  - (iii) Date of commencement
  - (iv) Actual and Scheduled Date of completion of the Work.
- (2) **The Works indicated in Annexure- 3 will only be considered for evaluation.** Mere submission of Work Completion Certificate will not be considered as Eligible Assignments.
- (3) As regards the tenders submitted by the bidding firms under Central/ State Government and PSUs, authentication of Power of Attorney in favour of signatory/s to the tender, by Notary Public is exempted.
  - i) Details of facilities available in Tenderers' repair yard (owned or leased) located in 25Kms from w/Island where the repairs of Grabs are proposed to be carried out, in case the contract is awarded, as per Annexure.-5.
  - j) A statement duly certified by Chartered Accountant showing Average Financial turnover of the Bidder over the last three financial years ending 31<sup>st</sup> March, 2023 (2020-21, 2021-22 and 2022-23 ) (vide *Annexure-4*) supported by Audited Financial statements for the above three financial years.
  - k) Form of Bid duly signed and sealed
  - l) Bid document including all addenda/corrigenda
  - m) Copy of Registered Partnership Deed or Memorandum and Articles of Association of

the Company and Registration Certificate of the Company as the case may be. If tenderer is a proprietorship firm, a declaration to this effect shall be furnished in their letter head.

- n) Copies of GST, PAN, EPF and ESI registration
- o) Documentary proof for MSME registration, if applicable
- p) A declaration as per to the effect that (vide *Annexure-8 in the letter head of Tenderer*):-

1. No conditions are incorporated in the financial bid. In case any conditions are specified in the financial bid, the tender will be rejected summarily without making any further reference to the bidder.
2. We have not made any payment or illegal gratification to any persons/ authority connected with the bid process so as to influence the bid process and have not committed any offence under PC Act in connection with the bid.
3. We disclose with that we have \* made / not made payments or propose to be made to any intermediaries (agents) etc. in connection with the bid.
4. We do hereby confirm that no changes have been made in the tender document downloaded and submitted by us for the above bid. Port Tender document will be treated as authentic tender and if any discrepancy is noticed at any stage between the Port's tender document and the one submitted by the tenderer, the Port's document shall prevail.
5. We do hereby confirm that we have not been blacklisted or debarred by any Central/ State Government/ agency of Central/ State Government/ Public Sector Undertaking/ Regulatory Authority of India at the time of submission of this bid.
6. We do hereby confirm our acceptance that :-

- (i) All the costs, risks and responsibility of the Grabs during the execution of the Contract (ie. Commencing from the date of taking over of each Grab from the Employer by the Contractor for repairs to till delivery of the Grab back to Employer's premises after satisfactory completion of all the works as per the Scope of each Work order as per the Contract), shall be entirely vest with the Contractor.
- (ii) The Contractor is wholly responsible to make good all the losses/damages that may be suffered by the Employer due to occurrence of any untoward incident (s), whatsoever it may be, at any stage during the execution the Contract, at the cost and risk of the Contractor.
- (iii) In case termination of the Contract either by Employer or Contractor, the Contractor is liable to safely transit and handover the Grab to the Employer at Cochin Port premises as per the terms of Termination of the Contract.

- q) Details of litigation history, blacklisting etc. of the Bidder, if any
- r). Contract Data as Annexure -10
- s) Bank information for e- Payment system as per *Annexure- 11*.

21.2. **Part-II : Price Bid**" shall contain (Bill of Quantities) Schedule I & Schedule II shall be duly filled in and fully priced, which shall be submitted only **in e-tendering mode**.

**22. List of Documents to be submitted:**

**22.1. List of Documents to be uploaded for online submission of Technical Bid :**

- (i) Scanned copy of financial instruments towards cost of Tender Document/ evidence of payment of Cost of Tender Document online or scanned copy of Exemption Certificate, as the case may be.
- (ii) Letter of Submission, as per format at **Annexure-1**.
- (iii) Power of Attorney in favour of signatory/s to the Tender, duly authenticated by Notary

Public, as per format at **Annexure-2**.

- (iv) Scanned copy of financial instruments towards EMD or scanned notarized copy of Exemption Certificate, as the case may be.
- (v) Scanned copies of **Annexures- 3 to 11**, duly signed
- (vi) Scanned copy of Form of Bid duly filled, signed and sealed as per Annexure-9
- (vii) Scanned copy of Partnership Deed or Memorandum and Articles of Association of the Company and Registration Certificate of the Company as the case may be. If tenderer is a proprietorship firm, a declaration to this effect shall be furnished in their letter head.
- (viii) Scanned notarized copies of Work Orders and completion certificates of similar Works
- (ix) Scanned copies of Audited Financial statements for the last three years ending 31-03-2023.
- (x) Technical Bid document including all addenda/corrigenda and General Conditions of Contract with Amendments in PDF format except Section V, Bill of Quantities (Price Schedules).
- (xi) Copies of PAN, GST, EPF and ESI registration

**22.2. List of documents to be submitted in original.**

- (i) DD / Pay Order/ Bankers Cheque towards Cost of Tender Document.
- (ii) DD / Pay Order/ Bankers Cheque towards EMD.
- (iii) Letter of Submission (vide **Annexure-1**)
- (iv) Power of Attorney, duly authenticated by Notary Public (vide **Annexure-2**)
- (v) Copy of documentary proof of MSME/NSIC registration (if applicable)

22.2.1. The Bidder shall submit original documents in a sealed cover, superscribing thereon the Tender Number, Name of Work, date notified for submission of tender and the name and address of the tenderer, either in person or sent by registered post / courier to the Deputy Conservator, Cochin Port Authority, Willingdon Island, Cochin, 682009, KERALA, on or before the last date and time of submission of bids. Non submission of the original instrument towards cost of tender document, EMD before the opening date and time will make the tender liable for rejection.

22.3. **Part II: Financial Bid:** Tenderers shall submit the BOQ/ Price Schedule I&II in the online portal [www.tenderwizard.com/CPT](http://www.tenderwizard.com/CPT) only. Otherwise, the tender will be rejected.

22.4. Tenders shall be submitted online strictly in accordance with the Instructions to Tenderers and Terms and Conditions given in the tender document. The bidders should submit scanned copy of all the documents including instruments towards the cost of tender; proof of experience, financial details etc. through the e-tendering portal.

**23. Deadline for Submission of the Bids:**

23.1. E-tenders attaching all documents shall be submitted 'on-line' in the e-tender portal strictly in accordance with the terms and conditions of the tender document before the time and the date notified in Table 1.2 of NIT.

24. **Late Bids:** Any Bid received by the Employer after the Bid due date will be returned unopened to the Bidder.

**25. Bid Opening – Technical Bid:**

25.1. **Technical Bid:** Original Documents as mentioned at Clause 21.2. Above shall be opened in the office of the **Deputy Conservator, Cochin Port Authority after 15.30 Hours** on the last date fixed for receiving the Tenders. Submission of Cost of Tender document and EMD will be verified initially. In case the above documents are not deposited or are not in order, the Bid will not be opened further and hard copy submitted will be returned.

25.2. Technical Bid shall be opened in the online Portal, [www.tenderwizard.com/CPT](http://www.tenderwizard.com/CPT) on the date and time fixed for tender opening.

**26. Bid Opening – Financial Bid:**

26.1. Financial Bid of those tenderers who are found qualified after evaluation of Technical Bids will be opened “on-line”. Date and time of opening of Price Bid will be intimated to the qualified bidders. Qualified bidders can witness opening of Price Bid by logging into the e-tender Portal, [www.tenderwizard.com/CPT](http://www.tenderwizard.com/CPT) on the date and time intimated for opening of Price Bid.

**27. Clarification of Bids:**

To assist in the examination and comparison of Bids, the Employer may, at his discretion, ask any Bidder for clarification of his Bid. The request for clarification and the response shall be in writing, but no change in the price or substance of the Bid shall be sought, offered, or permitted.

No Bidder shall contact the Employer on any matter relating to his Bid from the time of the Bid opening to the time the contract is awarded.

Any effort by the Bidder to influence the Employer’s Bid evaluation, Bid comparison or contract award decisions, may result in the rejection of his Bid.

**28. Examination of Bids and Determination of Responsiveness:**

28.1. Prior to detailed evaluation of Bids, Cochin Port will determine whether each Bid

- (a) Meets the Minimum Eligibility Criteria defined in Clause 13.
- (b) Has been properly signed by an authorized signatory (accredited representative) holding Power of Attorney in his favour. The Power of Attorney shall inter alia include a provision to bind the Bidder to settlement of disputes clause.
- (c) Is accompanied by the required Tender Document fee and Bid Security Declaration.
- (d) Is responsive to the requirements of the Bidding documents.

A responsive bid is one which conforms to all the terms, conditions and specification of the bidding documents, without material deviation or reservation. A material deviation or reservation is one which affects in any substantial way the scope, quality or performance of the Works;

- (i) which limits in any substantial way, the Employer’s rights or the Bidder’s obligations under the Contract; or
- (ii) Whose rectification would affect unfairly the competitive position of other Bidders presenting responsive Bids.
- (iii) undertakes in the Technical Bid that he has not incorporated any conditions in the Price Bid

28.2.If a Bid is not substantially responsive, it shall be rejected by the Employer, and may not subsequently be made responsive by correction or withdrawal of the non-conforming deviation or reservation.

**29. Evaluation of price Bid :**

- a. Only those tenders, as determined to be substantially responsive to the requirements of the Tender Documents will be evaluated. Other non-responsive tenders will be rejected. Cochin Port’s decision on this shall be final, conclusive and binding. A tender that is seriously unbalanced in relation to the cost estimate of Cochin Port, may be rejected as non-responsive.
- b. **Price bids shall be evaluated based on the Grand total cost quoted by the bidder in the price schedules I &II.** Rate for each line items will not be considered for price evaluation
- c. The offered unit rates for each line items in Price schedule I&II (BOQ) shall be filled by the bidder in figures only. The grand total amount in figure and words will appear automatically. The Bidders should ensure that his offered rates as per the Financial Bid is

not mentioned anywhere in any other documents in Technical Bid submission, directly or indirectly. If any such mention is made, the tender will become invalid and shall become liable for rejection.

- d. In order to determine the lowest evaluated bid, Cochin Port will consider the grand total amount of price schedule I&II.

**30. Alteration of tender documents:**

30.1. No alteration shall be made in any of the Tender Documents or in the Bill of Quantities and the tender shall comply strictly with the terms and conditions of the Tender Document. The Employer may however ask any Bidder for clarifications of his tender if required. Nevertheless, no Bidder will be permitted to alter his tender price after opening of the tender.

31. **Alternative Conditions and Proposals:** The Bidder shall note that alternative proposal for whole or part of the Work will not be acceptable. Tenders containing any qualifying conditions or even Bidder's clarifications in any form will be treated as non-responsive and will run the risk of rejection. Price Bid of such Bidder's will not be opened.

**32. Award of Contract:**

The Employer will award the Contract to the Bidder whose Bid has been determined to be responsive to the Bidding documents and who has offered the lowest evaluated Bid price, provided that such Bidder has been determined to be:

- (i) Eligible in accordance with the provisions of Clause 13, and
- (ii) Qualified in accordance with the provisions of Clause 13.

**33. Notification of Award:**

33.1. The Bidder whose Bid has been accepted will be notified about the award by the Employer prior to the expiry of the Bid Validity period by email or facsimile, confirmed by registered letter. This letter (hereinafter and in the Conditions of Contract called the "Letter of Acceptance") will state the sum that the Employer will pay the Contractor in consideration of the execution, completion and maintenance of the Works by the Contractor as prescribed by the Contract (hereinafter and in the Contract called the "Contract Price").

33.2. The notification of award will constitute the formation of the Contract subject only to the furnishing of a Performance Security in accordance with the provisions of Clause 34.

**34. Performance Security / Security Deposit:**

34.1. The successful bidder is required to submit Security Deposit within 21 days from the date of Letter of Acceptance (LoA), to guarantee fulfillment of performance and the obligations of the contract, in any one of the following forms:-

- (a) Account Payee Demand Draft/Banker's Cheque/Pay Order of a Nationalised/ Scheduled Indian Bank having its branch at Kochi in favour of FA&CAO, Cochin Port Authority.
- (b) An irrevocable and unconditional Bank Guarantee as per the Format enclosed in Annexure-13 of the tender document, drawn from any Nationalised /Scheduled Indian bank having its branch at Cochin acceptable by Cochin Port .
- (c) On-line payment to the Bank Account of Cochin Port indicated in Clause 1.6 of Notice Inviting Tender.

34.2. The value of Security Deposit shall be equivalent to 10 % of the total estimated contract value excluding GST for the repairs of anticipated 24 nos Grabs as per the rates quoted by the successful bidder and as indicated in the LAO/Work order.

34.3. In case the Security Deposit is furnished in the form of Bank Guarantee, the same should remain valid for a period of **30 months** from the date of LOA/Work order.

34.4. Cochin Port Authority is not bound to pay interest on the Security Deposit furnished by the successful bidder.

**35. Sanctions for Violations:**

35.1. Any breach of the aforesaid provisions by the Bidder or any one employed by it or acting on its behalf (whether with or without the knowledge of the Bidder) shall entitle the Employer to take all or any one of the following actions, wherever required:-

- (i) The Security Deposit/Performance Guarantee shall stand forfeited either fully or partially, as decided by the Employer and the Employer shall not be required to assign any reason therefore.
- (ii) To immediately cancel the contract, if already signed, without giving any compensation to the Bidder.
- (iii) To cancel all or any other Contracts with the Bidder. The Bidder shall, be liable to pay compensation for any loss or damage to the Employer resulting from such cancellation/rescission and the Employer shall be entitled to deduct the amount so payable from the money(s) due to the Bidder.
- (iv) To debar the Bidder from participating in future Bidding processes of the Government of India for a minimum period of five years, which may be further extended at the discretion of the Employer.
- (v) To recover all sums paid in violation of the Bid by Bidder (s) to any middleman or agent or broker with a view to securing the contract.
- (vi) Forfeiture of Performance Guarantee in case of a decision by the Employer to forfeit the same without assigning any reason for imposing sanction for violation of this Bid.

35.2. The Employer will be entitled to take all or any of the actions mentioned above by the Bidder or any one employed by it or acting on its behalf (whether with or without the knowledge of the Bidder), of an offence as defined in Chapter IX of the Indian Penal code, 1860 or Prevention of Corruption Act, 1988 or any other statute enacted for prevention of corruption.

35.3. The decision of the Employer to the effect that a breach of the provisions of this Bid has been committed by the Bidder shall be final and conclusive on the Bidder.

35.4. In the event of the Contractor failing to honour any of the commitments entered into under this Contract, Cochin Port Authority shall have unconditional option to encash the Security Deposit. The bank shall be obliged to make payment to Cochin Port Authority upon demand.

35.5. In the event of the tenderer, after the issue of the communication of acceptance of offer by the Board, failing / refusing to execute the agreement as hereinafter provided, the tenderer shall be deemed to have abandoned the contract and such an act shall amount to and be construed as the Contractor's calculated and the willful breach of the contract, the cost and consequence of which shall be to the sole account of the tenderer and upon such an event the Board shall have full right to claim damages.

**36. Signing of Agreement:**

36.1. The successful tenderer will be required to execute an Agreement at his expense within 28 days from the date of Letter of Acceptance (LoA), on proper value Kerala State Stamp Paper (Rs.200/- or above) in the prescribed form as per Annexure-12. The agreement as finally executed will include the Employer's Bid Documents and the Bidder's offer as finally accepted by the EMPLOYER together with addendum / corrigendum, bid clarification and all correspondences exchanged between EMPLOYER and the bidder, if any. Till the formal agreement is executed, the Letter of Acceptance together with the offer as finally accepted along with correspondences shall form a binding contract between the two parties.

**37. Fraud and Corrupt Practices:**

37.1. The bidder and their respective officers, employees, agents and advisers shall observe the highest standard of ethics during the Selection Process. Notwithstanding anything to the contrary contained in this document, the Port shall reject the tender without being liable in any manner whatsoever to the bidder, if it determines that the bidder has, directly or

indirectly or through an agent, engaged in corrupt practice, fraudulent practice, coercive practice, undesirable practice or restrictive practice (collectively the “Prohibited Practices”) in the Selection Process. In such an event, the Port shall, without prejudice to its any other rights or remedies, forfeit and appropriate the Bid Security or Performance Security, as the case may be, as mutually agreed genuine pre-estimated compensation and damages payable to the Port for, inter alia, time, cost and effort of the Authority, in regard to the Tender, including consideration and evaluation of such Bidder’s Proposal. Such Bidder shall not be eligible to participate in any tender or RFP issued by the Authority during a period of 2 (two) years from the date such Bidder is found by the Authority to have directly or through an agent, engaged or indulged in any corrupt practice, fraudulent practice, coercive practice, undesirable practice or restrictive practice, as the case may be.

37.2. For the purposes of this Clause, the following terms shall have the meaning hereinafter respectively assigned to them:

- (a) “corrupt practice” means
  - (i) the offering, giving, receiving, or soliciting, directly or indirectly, of anything of value to influence the action of any person connected with the Selection Process (for avoidance of doubt, offering of employment to or employing or engaging in any manner whatsoever, directly or indirectly, any official of the Authority who is or has been associated in any manner, directly or indirectly with the Selection Process or the LoA or has dealt with matters concerning the Agreement or arising there from, before or after the execution thereof, at any time prior to the expiry of one year from the date such official resigns or retires from or otherwise ceases to be in the service of the Authority, shall be deemed to constitute influencing the actions of a person connected with the Selection Process; or
  - (ii) engaging in any manner whatsoever, whether during the Selection Process or after the issue of the LoA or after the execution of the Agreement, as the case may be, any person in respect of any matter relating to the Project or the LoA or the Agreement, who at any time has been or is a legal, financial or technical consultant / adviser of the Authority in relation to any matter concerning the Project;
- (b) “fraudulent practice” means a misrepresentation or omission of facts or disclosure of incomplete facts, in order to influence the Selection Process;
- (c) “coercive practice” means impairing or harming or threatening to impair or harm, directly or indirectly, any persons or property to influence any person’s participation or action in the Selection Process;
- (d) “undesirable practice” means
  - (i) establishing contact with any person connected with or employed or engaged by the Authority with the objective of canvassing, lobbying or in any manner influencing or attempting to influence the Selection Process; or
  - (ii) having a Conflict of Interest; and
- (e) “Restrictive practice” means forming a cartel or arriving at any understanding or arrangement among Applicants with the objective of restricting or manipulating a full and fair competition in the Selection Process.

38. **Rejection of Tender:** Any Tender not conforming to the foregoing instructions will not be considered. The Employer does not bind himself to accept the lowest or any tender and has the right to reject or discharge the tender without assigning any reason.

Signature of the tenderer with seal

**COCHIN PORT AUTHORITY**

**SCHEDULE – I**

**3. LIST OF DOCUMENTS TO BE SUBMITTED BY THE TENDERER**  
**IN PART-I, TECHNICAL BID**

Sl. No	Clause Ref. No.	Description of Documents	Whether submitted by the Tenderer (Yes/No.) & Ref. of page No.
1	Table 1.4 (iii) of Notice Inviting Tender	Cost of Tender Documents – Rs.3540/- (Rs.3,000 + 18% GST) (Rupees Three thousand Three Hundred and Sixty only) in the form of DD/ Banker's cheque or online payment.	
2	Table 1.4 (ii) of Notice Inviting Tender	EMD/Bid Security	
3	Cl.No.20.1 (c) of Instruction to Tenderer	Letter of submission as per Annexure-I	
4	Cl.No.20.1 (d) of Instruction to Tenderer	Power of Attorney duly authenticated by Notary Public as per Annexure-2	
5	Clause 20.1. (k)	Form of Bid duly filled and signed as per Annexure-9.	
7	Clause 20.1. (r)	Contract Data duly filled and signed as per Annexure-10.	
8	Cl.No.13 of Instruction to Tenderer	Information regarding experience of having executed similar works as per Annexure-3 along with notarized copies of works orders and work completion certificate issued by the Clients.	
9	Cl.No.13 of Instruction to Tenderer	Statement of Average Annual Financial Turnover during last three years ending 31-03-2023 certified by Chartered Accountant as per Annexure-4 along with audited financial statements.	
12	Clause 20.1. (f)	Organisation Details of the Tenderer as per Annexure -6	
13	Clause 20.1. (g)	Details of Concurrent Commitments of the Tenderer as per Annexure-7	
14	Clause 20.1. (p)	Declaration as per Annexure-8	
16	Clause 20.1. (s)	Format for Furnishing Bank information for e-payment as Annexure-11	

17	Cl.No.21.1 of Instruction to Tenderer(x)	Tender document duly filled in <b>except Price Schedule I&amp;II</b> and addendum, duly signed and stamped.	
18	Cl.No.21.1 (vi) of Instruction to Tenderer	Partnership Deed or Memorandum and Article of Association of the Company and Registration Certificate of the company, Proprietorship Declaration as applicable.	
19	Cl.No.21.1 (xi) of Instruction to Tenderer	Documents in support of PAN,GST, EPF, ESI Registration	
20	Cl.No.20.1 (o) of Instruction to Tenderer	Documentary Proof of MSME/NSIC registration, if applicable	
21	Cl.No.20.1 (q) of Instruction to Tenderer	Detailed information regarding current litigation, if any, in which the tenderer is currently involved.	
22	Clause 15.1 of Instruction to bidders	Confirmation that the Tenderer has quoted their prices for all the line items of Price schedule I&II of Works as applicable.	

Note: All the documents submitted by the tenderer shall be page numbered. Tenderer is required to mention relevant page numbers / marking of his offer while filling up the above format.

Signature of Tenderer with seal

**COCHIN PORT AUTHORITY**

**4. ANNEXURES**

<b>Sl. No.</b>	<b>Annexure</b>	<b>Description</b>	<b>Page No.</b>
1	1	Letter of Submission	26
2	2	Proforma of Power-of-Attorney / Letter of Authority	27
3	3	Details of Past Experience of Contractors for Similar Works	28
4	4	Statement of Average Annual Financial Turnover	29
5	5	Details of Repair yard of Tenderer	30
6	6	Organization Details	31
7	7	Concurrent Commitments of the Tenderer	32
8	8	Declaration	33
9	9	Form of bid	34
10	10	Contract Data	37
11	11	Format for Furnishing Bank information for e-payment	40
12	12	Form of Agreement	41
13	13	Proforma of Bank Guarantee for Performance Guarantee/ Security Deposit	43
14	14	Format of No Claim Certificate	45

**COCHIN PORT AUTHORITY**

LETTER OF SUBMISSION- COVERING LETTER  
(ON THE LETTER HEAD OF THE BIDDER)

Date :

To

The Deputy Conservator,  
Cochin Port Authority.

Sir,

Sub : “Rate Contract for Repairs of Grabs of CoPA’s Grab Hopper Dredger Nehru Shatabdi for Two years” .

Being duly authorized to represent and act on behalf of ..... (Hereinafter referred to as “the Bidder”) and having reviewed and fully understood all of the requirements of the bid document and information provided, the undersigned hereby apply for the work referred above.

We are submitting our Bid enclosing the following, with the details as per the requirements of the Bid Document, for your evaluation.

- (i) Tender Document along with Addendum No. ----
- (ii) Cost of Tender Document vide .....or MSME/NSIC Registration, if applicable.
- (iii) Power of Attorney (Annexure- 2)
- (iv) EMD/Bid Security or MSME/NSIC Registration, if applicable.
- (v) Details of the past experience of similar works to fulfill the “Minimum Eligibility Criteria” (Annexure 3), work orders and work completion certificates;
- (vi) Statement duly certified by Chartered Accountant showing Average Annual Financial Turnover during the last 3 Financial years ending 31-03-2023 (Annexure-4);
- (vii) Audited Financial Statements for the last three financial years ending 31-03-2023.
- (viii) Detail of Tenderer’s Repair Yard to undertake the repairs (Annexure-5);
- (ix) Organization Details (Annexure-6)
- (x) Details of Concurrent Commitments (Annexure-7)
- (xi) Declaration (Annexure –8)
- (xii) Form of Bid (Annexure-9)
- (xiii) Contract Data (Annexure-10);
- (xiv) Bank Information of the Bidder (Annexure-11)

Signature

(Authorised Signatory)

**PROFORMA OF POWER- OF-ATTORNEY/LETTER OF AUTHORITY**

(To be submitted on Non-judicial **Stamp Paper of R.200/-** and should be authenticated by Notary Public/)

To

The Deputy Conservator,  
Cochin Port Authority,  
Cochin 682009.  
Kerala, India.

Dear Sir,

We \_\_\_\_\_

do hereby confirm that Mr./Ms./Messrs \_\_\_\_\_ [***INSERT NAME AND ADDRESS***], whose signature is given below, is /are authorized to represent us to bid, negotiate and conclude the agreement on our behalf with you against Tender for “Rate Contract for Repairs of Grabs of CoPA’s Grab Hopper Dredger Nehru Shatabdi for Two years”. TENDER No.MD/PMW/ GHDNS GRAB REPAIRS/2025-26 .We confirm that we shall be bound by all and whatsoever our said agents shall commit.

Signature of the authorized person:

Name & Designation :

Yours faithfully,

Signature, name and seal of the certifying authority

**Annexure 3**

**DETAILS OF SIMILAR WORKS COMPLETED BY THE TENDERER DURING  
THE LAST SEVEN YEARS ENDING 31-10-2024**

Sl. No.	Work Order No.& date, by whom issued and brief description of work	Total work order value and completion cost (in INR).	Actual date of commencement of work	Actual date of completion of work	Delays if any	Client's complete address with e-mail address and phone number of contact person
1	2	3	4	5	6	7
<b>1</b>						
<b>2</b>						
<b>3</b>						

**Note: Bidder shall enclose copies of each work orders & completion certificate issued by Client, certified by a Notary Public or equivalent certifying authority.**

**SIGNATURE OF TENDERER**

**COCHIN PORT AUTHORITY**

**FINANCIAL CAPABILITY**  
**AVERAGE ANNUAL TURNOVER OF THE BIDDER**

<b><u>Turnover (INR)</u></b>			
<b>Year 1</b> [2020 – 21]	<b>Year 2</b> [2021 – 22]	<b>Year 3</b> [2022 – 23]	<b>Average of</b> <b>3 years</b>

**Instructions:**

- 1) The Bidder shall provide audited Annual Reports / Audited financial statements such as Balance Sheets and Profit & Loss Account statements as required under this Bid Document.
- 2) Annual Turnover of the Bidder shall be submitted duly verified by Chartered Accountant or Competent Authority.

**Certified by**  
**Chartered Accountant**

**SIGNATURE OF TENDERER**

**Annexure – 5.**

**COCHIN PORT AUTHORITY**

**DETAILS OF REPAIR YARD OF THE TENDERER WHERE THE REPAIRS OF GRABS ARE PROPOSED  
TO BE CARRIED OUT IN CASE THE CONTRACT IS AWARDED**

Sl. No.	Name and address of the Repair Yard and state whether owned by tenderer or leased by the Tenderer.(Furnish copy of Registration certificate of the Tenderer. In case, the tenderers repair yard is leased, copy of lease agreement shall also be furnished)
1	2
1	

**SIGNATURE OF TENDERER**

**COCHIN PORT AUTHORITY**

**ORGANIZATION DETAILS**

- 1) Name of Applicant :
- 2) Name of the Owner :
- 3) Address :
  
- 4) Telephone No. :
- 5) E-mail id [2 nos.] :
- 6) Fax No. :
- 7) Description of Applicant with details :  
(for e.g. Individual, Partnership, Limited Company etc)
- 8) Registration details :
- 9) Name and address of bankers :
- 10) Number of years of experience :  
as a Repair Yard
- 11) Name and address of the companies/ :  
Sub-Contractors who will be involved  
in the execution of Works, namely:
- 12) Attach organization chart showing the structure  
of the company including names of Directors/  
Key Personnel at Head Office who would be  
responsible for the project.

**SIGNATURE OF TENDERER**

**COCHIN PORT AUTHORITY**

CONCURRENT COMMITMENTS

Sl.No	Full postal address of client & Name of Officer- in-Charge with Fax/telephone No.	Description of the work.	Value of contract	Date of commencement of work.	Scheduled completion period (months)	% completion as on date
1						
2						
3						

**SIGNATURE OF TENDERER**

**COCHIN PORT AUTHORITY**

**DECLARATION**

We M/s .....(Name & address of the bidder) hereby declare that:-

1. No conditions are incorporated in the financial bid. In case any conditions are specified in the financial bid, the tender will be rejected summarily without making any further reference to the bidder.
2. We have not made any payment or illegal gratification to any persons/ authority connected with the bid process so as to influence the bid process and have not committed any offence under PC Act in connection with the bid.
3. We disclose with that we have \* made / not made payments or propose to be made to any intermediaries (agents) etc. in connection with the bid.
4. We do hereby confirm that no changes have been made in the tender document downloaded and submitted by us for the above bid. Port Tender document will be treated as authentic tender and if any discrepancy is noticed at any stage between the Port's tender document and the one submitted by the tenderer, the Port's document shall prevail.
5. We do hereby confirm that we have not been blacklisted or debarred by any Central/ State Government/ agency of Central/ State Government/ Public Sector Undertaking/ Regulatory Authority of India at the time of submission of this bid.
6. We do hereby confirm our acceptance that :-
  - i. All the costs, risks and responsibility of the Grabs during the execution of the Contract (ie. Commencing from the date of taking over of each Grab from the Employer by the Contractor for repairs to till delivery of the Grab back to Employer's premises after satisfactory completion of all the works as per the Scope of each Work order as per the Contract), shall be entirely vest with the Contractor.
  - ii) The Contractor is wholly responsible to make good all the losses/damages that may be suffered by the Employer due to occurrence of any untoward incident (s), whatsoever it may be, at any stage during the execution the Contract, at the cost and risk of the Contractor.
  - iii) In case termination of the Contract either by Employer or Contractor, the Contractor is liable to safely transit and handover the Grab to the Employer at Cochin Port premises as per the terms of Termination of the Contract.
7. We do hereby confirm that, our repair yard (either owned/leased) is located within 25 Kms from Willindon Island , Kerala, where the repairs of Grabs are proposed to be carried out in case the contract is awarded.

**\* Note: Delete whichever is not applicable.**

Authorised Signatory

**ANNEXURE-9**

**COCHIN PORT AUTHORITY**

**FORM OF BID**

**To**

The Board of Trustees,  
Cochin Port Authority

**Through**

The Deputy Conservator  
Cochin Port Authority, Cochin -9

Tender for “Rate Contract for Repairs of Grabs of CoPA’s Grab Hopper Dredger Nehru Shatabdi  
for Two years”

**I/We have read and examined the Notice inviting tenders, Instructions to tenderers, Form of Agreement, General Conditions of Contract, Special Conditions of Contract, Scope of Work & Technical Specification, Price schedules (Bill of Quantities) & other documents and rules referred to in the General Conditions of Contract and all other contents in the tender document.**

I/We hereby tender for the execution of the work specified in the underwritten memorandum at the rates specified in the schedule attached hereto and in accordance in all respects with the specifications designs, drawings and instructions in writing referred to in the Scope of Work and Technical Specification mentioned under Section IV of the Tender Document and with such materials as are provided for, by and in all other respects in accordance with such conditions so far as applicable.

**MEMORANDUM**

- |                                                                               |   |                                                                                             |
|-------------------------------------------------------------------------------|---|---------------------------------------------------------------------------------------------|
| a) General description of work                                                | : | “Rate Contract for Repairs of Grabs of CoPA’s Grab Hopper Dredger Nehru Shatabdi”           |
| b) Estimated Amount put to Tender.                                            | : | <b>Rs. 31,09,000.00</b> (Rupees Thirty One lakh Nine Thousand only) excluding GST           |
| b) Earnest Money                                                              | : | Rs 62,180/-                                                                                 |
| c) Security Deposit                                                           | : | 10% of the value of the contract awarded or the value of the work done whichever is higher. |
| d) Completion Period of work from the date of receipt of Letter of Acceptance | : | Two years from the date of LOA/Work Order                                                   |

**I/ We agree to keep the tender open for 90 days from the due date of submission and not to make any modifications in its terms and conditions.**

Should this tender be accepted, I/We hereby agree to abide by and fulfil all the terms and provisions of the said conditions of contract annexed hereto so far as applicable or in default thereof the cost and consequence of which shall be to the sole account of the tenderer and upon such an event the Board shall have full right to claim damages. I/We fully accept that, in the event of default, I/We will be suspended and shall not be eligible to participate in the Tenders invited by Cochin Port , for a period of Two years from the date of such Suspension Orders.

Dated the ..... day of ..... 2024

**SIGNATURE OF TENDERER**

Address :  
  
Witness :  
Address :  
Occupation :

**ACCEPTANCE**

**The above tender ( as modified by you as provided in the letters mentioned hereunder) is  
accepted by me for and on behalf of the Board of Trustees for a sum of Rs..... (**  
**Rupees.....)**

The letters referred to below shall form part of this Contract Agreement

- a) ..
- b) ..
- c)

Dated.....

**Deputy Conservator  
Cochin Port Authority**

**COCHIN PORT UTHORITY**  
**CONTRACT DATA**

Items marked “N/A” do not apply in this Contract.

Sl. No.	Description	Reference Clause No. in GCC												
1	<i>The following documents are also part of the Contract</i>													
	The Schedule of other Contractors : <b>N/A</b>	(8.2)												
	The Schedule of Key personnel: N/A	(9)												
	<table border="1" style="width: 100%; border-collapse: collapse;"> <thead> <tr> <th style="text-align: center;">Qualification of Staff</th> <th style="text-align: center;">No.</th> <th style="text-align: center;">Min. Experience (Years)</th> <th style="text-align: center;">Rate of recovery in case of non compliance</th> </tr> </thead> <tbody> <tr> <td style="text-align: center;">i) Graduate Engineer</td> <td></td> <td></td> <td></td> </tr> <tr> <td style="text-align: center;">ii) Graduate Engineer <b>or</b> Diploma Engineer</td> <td></td> <td></td> <td></td> </tr> </tbody> </table>	Qualification of Staff	No.	Min. Experience (Years)	Rate of recovery in case of non compliance	i) Graduate Engineer				ii) Graduate Engineer <b>or</b> Diploma Engineer				
Qualification of Staff	No.	Min. Experience (Years)	Rate of recovery in case of non compliance											
i) Graduate Engineer														
ii) Graduate Engineer <b>or</b> Diploma Engineer														
2	The Employer is	(1)												
	<b>The Board of Cochin Port Authority, Cochin -9.</b>													
	Name of Authorized Representative:													
	Name : Kasi Viswanathan <b>Chairperson, Cochin Port Authority, Cochin -9.</b>													
3	Tendering Authority is													
	Name : Capt. TM Kumar, Deputy Conservator, Cochin Port Authority,, Cochin -9.													
	Name of Nominee is : <b>Will be notified in LoA</b>													
4	Name of Contract :- “Rate Contract for Repairs of Grabs of CoPA’s Grab Hopper Dredger Nehru Shatabdi for Two years” TENDER No. MD/PMW/ GHDNS GRAB REPAIRS/2025-26	(1)												
5	Copies of Contract Agreement shall be furnished by the Contractor : 7 Copies	(7.1)												
6	Tender Document and other data are available at Cochin Port web site, central public procurement Portal and e –tendering portal. (i) <a href="http://www.cochinport.gov.in">www.cochinport.gov.in</a> (ii) <a href="http://www.eprocure.gov.in/cppp">www.eprocure.gov.in/cppp</a> (iii) <a href="http://tenderwizard.com/CPT">tenderwizard.com/CPT</a>	(7.2)												

Sl. No.	Description	Reference Clause No. in GCC				
7	<p>The Intended Completion Date for the whole of the Work with the following milestones is :</p> <p>Contract period is Two years from the date of LOA/Work Order. Separate work order will be issued for each Grab and the completion period of work for each Grab will Two Months from the date of each work order. (Strike out whichever is not applicable)</p> <table border="1" data-bbox="256 734 1118 925"> <tr> <td data-bbox="256 734 740 813">Physical Works to be completed</td> <td data-bbox="740 734 1118 813">Milestone applicable</td> </tr> <tr> <td data-bbox="256 813 740 925">Total completion period of the Contract as applicable as per the tender conditions.</td> <td data-bbox="740 813 1118 925">Two years from the date of LOA/Work Order</td> </tr> </table>	Physical Works to be completed	Milestone applicable	Total completion period of the Contract as applicable as per the tender conditions.	Two years from the date of LOA/Work Order	(17, 29, 49) of GCC and Clause 6 under Section III Special Conditions of Contract
Physical Works to be completed	Milestone applicable					
Total completion period of the Contract as applicable as per the tender conditions.	Two years from the date of LOA/Work Order					
8	<p>The following shall form part of the Contract Document:</p> <ol style="list-style-type: none"> <li>(1) Form of Agreement</li> <li>(2) Letter of Acceptance</li> <li>(3) Price Schedules I&amp;II (Bill of Quantities)</li> <li>(4) Contractor's Bid</li> <li>(5) Correspondence exchanged after the opening of the Bid and before the issue of Letter of Acceptance by which the Condition of Contract are amended, varied or modified in any way by mutual consent (to be enumerated).</li> <li>(6) Contract Data</li> <li>(7) Conditions of Contract</li> <li>(8) General Description and Special Conditions of Contract</li> <li>(9) Scope of work and Technical Specifications</li> <li>(10) Drawings, specifications; and</li> <li>(11) Any other documents listed in the Contract Data as forming part of the Contract.</li> </ol>	(2.3)				
9	The contractor shall submit a program for the works within ..... days of the date of LoA from CoPA.	(27) NA				
10	The Contractors Repair Yard located at.....					
11	The Defects Liability Period is Three months from the date fitting of each repaired Grab onboard the vessel	(35)				
12	The following events shall also be Compensation Events: N/A	(44)				
13	The period between Programme updates - NA	(27)				
14	The language of the Contract documents is <b>English.</b>	(3)				

<b>Sl. No.</b>	<b>Description</b>	<b>Reference Clause No. in GCC</b>
15	The law, which applies to the Contract, is the law of Union of India.	(3)
16	The currency of the Contract is <b>Indian Rupees.</b>	(46)
17	The maximum amount of Liquidated Damages for repairs of each Grabs is <b>10%</b> of the total repair cost of each Grab.	(49)
19	The amounts of the advance payments : NA	(51)

**SIGNATURE OF TENDERER**

**COCHIN PORT AUTHORITY**

“Rate Contract for Repairs of Grabs of CoPA’s Grab Hopper Dredger Nehru Shatabdi for Two years”

**FORMAT FOR FURNISHING BANK INFORMATION FOR e-PAYMENT**

1	Name and full address of the beneficiary	
2	Credit Account No. (Should be full 14 digit)	
3	Account Type (SB or CA or OD)	
4	Name of the Bank	
5	Branch (Full address with telephone No.)	
6	MICR code (Should be 9 digit)	
7	Telephone/Mobile/Fax No. of the beneficiary	Telephone: Mobile : Fax :
8	Cancelled Cheque	

**SIGNATURE OF TENDERER**

**COCHIN PORT AUTHORITY**

FORM OF AGREEMENT  
*TO BE EXECUTED ON KERALA STAMP PAPER (Rs.200/-)*

AGREEMENT NO. .... OF.....

This agreement is made at Cochin this the-----day of -----, Two Thousand----  
-..... between.....represented by Sri.....  
Aged.....years, son of Sri.....Residing at  
.....(House name and No.) .....  
.....District.....State .....

..... (hereinafter referred to as “The Contractor” which expression shall include their successors, assignees and administrators) of the one part AND the Board of Major Port Authority, Cochin Port, Willingdon Island, Cochin-9, a body constituted under “Major Port Authority Act 2021” represented by The Deputy Conservator (hereinafter referred to as “The Employer” which expression shall include their successors, assignees and administrators in the office) of the other part.

Whereas the “Employer” had called for the tenders for the work of “Rate Contract for Repairs of Grabs of CoPA’s Grab Hopper Dredger Nehru Shatabdi for Two years” and the Contractor had submitted a tender for the same giving the rates subject to the terms and conditions etc. And whereas the said tender of the Contractor has been accepted by the Employer and a Letter of Acceptance/Work Order No..... dated..... has been issued to the Contractor accepting their tender subject to Instructions to Tenderer, General Conditions of Contract, Special Conditions of Contract, Scope of Work & Technical Specification and such other Contract Documents. And as per one of the terms of the above Letter of Acceptance/Work Order, an agreement has to be executed between the Contractor and the Employer.

**NOW THESE PRESENTS WITNESES AS FOLLOWS:**

The Contractor hereby agrees to execute the work of “Rate Contract for Repairs of Grabs of CoPA’s Grab Hopper Dredger Nehru Shatabdi for Two years” as described in the schedule, its annexure etc. at the rates shown there under subject to Instructions to Tenderer, General Conditions of Contract, Special Conditions of Contract, Scope of Work & Technical Specification and such other Contract Documents all hereunto annexed within ..... days from the date of receipt of Work Order or in default to forfeit and pay to the employer the sum of money mentioned in the said conditions.

The Contractor has furnished a Bank Guarantee for Rs..... (Rupees. Only) vide Bank Guarantee No..... dated..... from.....Bank in lieu of Security Deposit for the due and proper fulfilment of the contract. The Contractor further agrees that the aforesaid Bank Guarantee will be kept valid until two months beyond the expiry of Defect liability period. The Contractor also agrees that the Bank Guarantee furnished in lieu of Security Deposit for the due and proper fulfilment of the contract will be suitably enhanced so as to cover 3% of cost of any additional items/works that may be required for the proper completion of the contract or otherwise the employer can deduct such additional amounts towards Security Deposit from the Contractor’s bills.

The following documents shall be deemed to form and be read and construed as part of this agreement viz:

*(list of relevant documents- will be furnished by Port)*

The Conditions given in the Letter of Acceptance/Work Order dated..... Shall over-ride the general conditions given in the tender document, wherever they differ. Any of the counter terms and conditions of the Contractor shall not be taken as terms and conditions of this contract/ agreement unless the Trustees in writing specifically agree to it.

IN WITNESS WHEREOF THE CONTRACTOR hereunto set his hand and seal And on behalf of the Board of Trustees of Port of Cochin, The Deputy Conservator has set his hand and seal and common seal of Trustees as has been hereunto affixed the day and year first written above.

Signed, sealed and delivered by Shri. .... of M/s .....

CONTRACTOR

-----

(COMMON SEAL OF THE FIRM)

Signed and affixed seal in the presence of:

Signature with address:

Signature with address:

Signed, sealed and delivered  
by the Deputy Conservator,  
Major Port Authority, Cochin Port on behalf of  
EMPLOYER (Board of Major Port Authority, Cochin Port).

Signed and affixed the  
common Seal of Board of  
Trustees of the Port of Cochin  
in the presence of

- 1)
- 2)

**PROFORMA OF BANK GUARANTEE FOR PERFORMANCE GUARANTEE/ SECURITY  
DEPOSIT**

*(To be executed on non-judicial Stamp Paper of appropriate value)*

*[The bank, as requested by the successful Tenderer, shall fill in this form in accordance with the instructions indicated]*

In consideration of the Board of Trustees of the Port of Cochin incorporated by the Board of Major Port Authority, Cochin Port, Willingdon Island, Cochin-9, a body constituted under “ Major Port Authority Act 2021” (hereinafter called “The Board” which expression shall unless excluded by or repugnant to the context or meaning thereof be deemed to include the Board of Trustees of the Port of Cochin, its successors and assigns) having agreed to exempt \_\_\_\_\_ (hereinafter called the “Contractor”)

\_\_\_\_\_  
(Name of the Contractor/s)

From the demand under the terms and conditions of the Contract, vide \_\_\_\_\_ ‘s letter No. \_\_\_\_\_

\_\_\_\_\_  
(Name of the Department)

date \_\_\_\_\_ made between the Contractors and the Board for execution of \_\_\_\_\_ covered under Tender No. \_\_\_\_\_ dated \_\_\_\_\_ (hereinafter called “the said contract”) for the payment of Security Deposit in cash or Lodgement of Government Promissory Loan Notes for the due fulfillment by the said Contractors of the terms and conditions of the said Contract, on production of a Bank Guarantee for Rs. \_\_\_\_\_ (Rupees \_\_\_\_\_) only we, the (Name of the Bank and Address) \_\_\_\_\_

\_\_\_\_\_ (hereinafter referred to as “the Bank”) at the request of the Contractors do hereby undertake to pay to the Board an amount not exceeding Rs. \_\_\_\_\_ (Rupees \_\_\_\_\_) only against any loss or damage caused to or suffered by or which would be caused to or suffered by the Board by reason of any breach by the Contractors of any of the terms and conditions of the said contract.

2. We, \_\_\_\_\_, \_\_\_\_\_, do hereby  
(Name of Bank) (Name of Branch)

undertake to pay the amounts due and payable under this guarantee without any demur merely on a demand from the Board stating that the amount claimed is due by way of loss or damage caused to or which would be caused to or suffered by the Board by reason of any breach by the Contractors of any of the terms and conditions of the said contract or by reason of the Contractors failure to perform the said contract. Any such demand made on the Bank shall be conclusive as regards the amount due and payable by the Bank under this Guarantee. However, our liability under this guarantee shall be restricted to any amount not exceeding Rs. \_\_\_\_\_ (Rupees \_\_\_\_\_) only.

3. We, \_\_\_\_\_(Name of Bank and Branch)\_\_\_\_\_, undertake to pay to the

Board any money so demanded notwithstanding any dispute or disputes raised by the Contractor(s) in any suit or proceeding pending before any Court or Tribunal relating thereto our liability under this present being absolute and unequivocal. The payment so made by us under this bond shall be a

valid discharge of our liability for payment there under and the Contractor(s) shall have no claim against us for making such payment.

4. We, \_\_\_\_\_(Name of Bank and Branch) further agree with the Board that the guarantee herein contained shall remain in full force and effect during the period that would be taken for performance of the said contract and that it shall continue to be enforceable till all the dues of the Board under or by virtue of the said contract have been fully paid and its claims satisfied or discharged or till the \_\_\_\_\_

(Name of the user department)

of the said certifies that the terms and conditions of the said contract have been fully and properly carried out by the said Contractors and accordingly discharge this guarantee. PROVIDED HOWEVER that the Bank shall be the request of the Board but at the cost of the Contractors, renew or extend this guarantee for such further period or periods as the Board may require from time to time.

5. We, \_\_\_\_\_ further agree with the Board  
(Name of Bank and Branch)

that the Board shall have the fullest liberty without our consent and without affecting in any manner our obligations hereunder to vary any of the terms and conditions of the said contract or to extend the time of performance by the said contract or to extend the time of performance by the said Contractors from time to time or to postpone for any time or from time to time any of the powers exercisable by the Board against the said Contractors and to forbear or enforce any of the terms and conditions relating to the said contract and we shall not be relieved from our liability by reason of any such variation or extensions being granted to the Contractors or for any forbearance, act or omission on the part of the Board or any indulgence shown by the Board to the Contractors or by any such matter or thing whatsoever which under the law relating to sureties would, but for this provision, have effect of so relieving us.

6. This guarantee will not be discharged due to the change in the constitution of the Bank or the Contractor(s).

7. It is also hereby agreed that the Courts in Kochi would have exclusive jurisdiction in respect of claims, if any, under this Guarantee.

8. We, \_\_\_\_\_ Bank lastly undertake not to revoke this guarantee during its currency except with the previous consent of the Board in writing.

9. Notwithstanding anything contained herein:

a) Our liability under this Bank Guarantee shall not exceed Rs. \_\_\_\_\_

(Rupees \_\_\_\_\_ only);

b) this Bank Guarantee shall be valid upto \_\_\_\* \_\_\_\_\_; and

c) we are liable to pay the guarantee amount or any part thereof under this Bank Guarantee only and only if you serve upon us a written claim or demand on or before \_\_\_\_\_ (date of expiry of Guarantee).”

Date \_\_\_\_\_ day of \_\_\_\_\_ 20

For (Name of Bank)  
(Name)

Signature

NO CLAIM CERTIFICATE

(On Company Letterhead)  
To,  
(Contract Executing Officer)  
Cochin Port Authority

Sub: **Contract Agreement No ----- dated -----for -----**

We have received the sum of Rs. (Rupees \_\_\_\_\_only) in full and final settlement of all the payments due from Cochin Port Authority for ..... under the abovementioned contract agreement, between us and Cochin Port Authority. We hereby unconditionally, and without any reservation whatsoever, certify that with this payment, we shall have no claim, whatsoever of any description, on any account, against Cochin Port Authority, against aforesaid Contract Agreement executed by us.

Yours faithfully,

Signatures of Contractor or  
Officer authorized to sign the Contract Documents  
On behalf of the Contractor  
(Company Stamp)

Date:  
Place:

**Section II. GENERAL CONDITIONS OF  
CONTRACT**

**A.General**

**1 Definitions**

Terms which are defined in the Contract Data are not also defined in the Conditions of Contract but keep their defined meanings. Capital initials are used to identify defined terms.

**Bill of Quantities** means the priced and completed Bill of Quantities forming part of the Bid.

**Compensation Events** are those defined in Clause 44

The **Completion Date** is the date of completion of the Works as certified by the Engineer or his nominee in accordance with Sub Clause 55.1

The **Contract** is the contract between the Employer and the Contractor to execute, complete and maintain the Works. It consists of the documents listed in Clause 2.3 below.

The **Contract Data** defines the documents and other information which comprise the Contract

The **Contractor** is a person or corporate body whose Bid to carry out the Works has been accepted by the Employer.

The **Contractor's Bid** is the completed Bidding documents submitted by the Contractor to the Employer.

The **Contract Price** is the price stated in the letter of acceptance and thereafter as adjusted in accordance with the provisions of the Contract.

**Days** are calendar days, **months** are calendar months.

A **Defect** is any part of the Works not completed in accordance with the Contract.

The **Defects Liability Period** is the period named in the Contract Data and calculated from the Completion Date.

The **Employer** is the party who will employ the Contractor to carry out the Works.

**Equipment** is the Contractor's machinery and vehicles brought temporarily to the Site to construct the Works.

The **Initial Contract Price** is the Contract Price listed in the Employer's Letter of Acceptance.

The **Intended Completion Date** is the date on which it is intended that the Contractor shall complete the works. The Intended Completion Date is specified in the Contract Data. The Intended Completion Date may be revised only by the Engineer or his nominee by issuing an extension of time.

**Market Rate** is the rate as decided by the Engineer on the basis of the cost of materials and labour at the site where the work is to be executed plus 10% to cover all overheads and profits.

**Materials** are all supplies, including consumables, used by the Contractor for incorporation in the Works.

The **Engineer or his nominee** is the person named in the Contract Data (or any other competent person appointed and notified to the Contractor to act in replacement of the Engineer or his nominee) who is responsible for supervising the Contractor, administering the Contract, certifying payments due to the Contractor, issuing and valuing Variations to the Contract, awarding extensions of time and valuing the Compensation Events.

**Plant** is any integral part of the Works which is to have mechanical, electrical, electronic or chemical or biological function.

**Ruling Percentage** is the percentage by which the tendered amount of the works actually awarded is higher or lower than the corresponding estimated amount of the works actually awarded.

The **Site** is the area defined as such in the Contract Data.

**Site Investigation Reports** are those which were included in the Bidding documents and are factual interpretative reports about the surface and sub-surface conditions at the site.

**Specification** means the Specification of the Works included in the Contract and any modification or addition made or approved by the Engineer or his nominee.

The **Start Date** is given in the Contract Data. It is the date when the Contractor shall commence execution of the works. It does not necessarily coincide with any of the Site Possession Date.

A **Sub Contractor** is a person or corporate body who has a Contract with the Contractor to carry out a part of the work in the Contract which includes work on the Site.

**Temporary Works** are works designed, constructed, installed and removed by the Contractor which are needed for construction or installation of the Works

A **Variation** is an instruction given by the Engineer or his nominee which varies the Original Works.

The **Works** are what the Contract requires the Contractor to construct, install and turn over to the Employer as defined in the Contract Data.

## 2. **Interpretation**

In interpreting these Conditions of Contract, singular also means plural, male also means female or neuter and the other way around. Headings have no significance. Words have their normal meaning under the language of the Contract unless specifically defined. The Engineer or his nominee will provide instructions clarifying queries about the Conditions of Contract.

If sectional completion is specified in the Contract Data, references in the Conditions of Contract to the Works, the Completion Date, and the Intended Completion Date apply to any Section of the Works (other than references to the Completion Date and Intended Completion date for the whole of the Works).

The documents forming the Contract shall be interpreted in the following order of priority:

- (1) Agreement
- (2) Letter of Acceptance and notice to proceed with works
- (3) Contractor's Bid
- (4) Contract Data
- (5) Conditions of Contract including Special Conditions of Contract
- (6) Specifications
- (7) Drawings
- (8) Bill of quantities and
- (9) Any other documents listed in the Contract Data as forming part of the Contract.

## 3 **Language and Law**

The language of the Contract and the law governing the Contract are stated in the Contract Data.

## 4 **Engineer or his nominee's Decisions**

Except where otherwise specifically stated, the Engineer or his nominee will decide contractual matters between the Employer and the Contractor in the role representing the Employer.

5 **Delegation**

The Engineer or his nominee may delegate any of the duties and responsibilities to other people after notifying the Contractor and may cancel any delegation after notifying the Contractor.

6 **Communications**

Communications between parties which are referred to in the conditions are effective only when in writing. A notice shall be effective only when it is delivered (in terms of Indian Contract Act 1872).

7 **Contract Agreement**

A suitable form is annexed as –FORM OF AGREEMENTI to the Tender Document. Upon signing the Contract Agreement, the Contractor shall make copies of Contract Documents, as indicated in the Contract Data, in hardbound cover which shall cover documents used in Contract/Agreement and provide the same to the Employer at no extra cost.

Data made available by the Employer in accordance with provisions of the Condition of Contract shall be deemed to include data listed elsewhere in the Contract and open for inspection at the office of the Engineer as indicated in the Contract data of the Cochin Port Authority (by prior appointment with the Engineer).

8 **Subcontracting**

The Contractor may subcontract with the approval of the Engineer or his nominee but may not assign the Contract without the approval of the Employer in writing. Subcontracting does not alter the Contractor's obligations.

Notwithstanding any subcontracting with such approval as required under above and notwithstanding that the Engineer shall have received copies of any sub-contract, the Contractor shall be solely responsible for the quality and proper execution of the works, performance of all conditions of contract in all respects as if such subletting had not taken place and as if such work has been done directly by the Contractor.

If any Sub-Contractor engaged upon the works at the site executes any work, which in the opinion of the Engineer or his nominee is not in accordance with the Contract condition, written notice may be given to the Contractor requesting him to terminate such sub contract and the Contractor, upon receipt of such notice shall terminate such sub contract and the said Sub Contractor shall forthwith leave the works, failing which the Employer shall have right to remove such Sub Contractors from site. No action taken by the Employer under this clause shall relieve the Contractor of any of his liabilities under the contract or give rise to any compensation, extension of time or otherwise.

**Other Contractors**

The Contractor shall co-operate and share the site with other Contractors, public authorities, utilities and the Employer between the dates given in the Schedule of other Contractors. The Contractor shall as referred to in the Contract Data, also provide facilities and services for them as described in the Schedule. The Employer may modify the schedule of other Contractors and shall notify the Contractor of any such modification.

9 **Personnel**

The Contractor shall employ the key personnel named in the Schedule of Key Personnel as referred to in the Contract Data to carry out the functions stated in the Schedule or other personnel approved by the Engineer or his nominee. The Engineer or

his nominee will approve any proposed replacement of key personnel only if their qualifications, abilities, and relevant experience are substantially equal to or better than those of the personnel listed in the schedule.

If the Engineer or his nominee asks the Contractor to remove a person who is a member of the Contractor's staff from his work force stating the reasons, the Contractor shall ensure that the person leaves the site within seven days and has no further connections with the work in the contract.

**10 Employer's and Contractor's Risks**

The Employer carries the risks which this Contract states are Employer's risks and the Contractor carries the risks which this Contract states are Contractor's risks.

**11 Employer's Risks**

The Employers risks are

- (a) Loss or damage due to the use or occupation by the Employer of any Section or part of the Permanent Works, except as may be provided for in the Contract;
- (b) Loss or damage to the extent that it is due to the design of the Works, other than any part of the design provided by the Contractor or for which the Contractor is responsible; and
- (c) Any operation of the forces of nature (in so far as it occurs on the Site) which an experienced Contractor:
  - (i) could not have reasonably foreseen, or
  - (ii) could reasonably have foreseen, but against which he could not reasonably have taken at least one of the following measures:
    - (A) prevent loss or damage to physical property from occurring by taking appropriate measures, or
    - (B) insure against.

**12 Contractor's Risks**

All risks of loss of or damage to physical property and of personal injury and death which arise during and in consequence of the performance of the Contract other than the excepted risks are the responsibility of the Contractor.

Excepted risks are riot (in so far as it is uninsurable) war, invasion, act of foreign enemies, hostilities (whether war be declared or not), civil war, rebellion, revolution, insurrection or military usurped power or a cause solely due to use of occupation by the Employer of any portion of the work, any operation of the forces of nature that the Contractor could not have foreseen or reasonably provided against. (All of such are herein collectively referred to as the excepted risks).

**13 Insurance**

The Contractor shall provide in the joint names of the Employer and the Contractor, insurance cover from the Start Date to the end of the Defects Liability Period, in the amounts and deductibles stated in the Contract Data for the following events which are due to the Contractors risks.

- a) loss of or damage to the Works, Plant and Materials
- b) loss of or damage to Equipment;
- c) loss of or damage of property (except the Works, Plant, Materials and Equipment) in connection with the Contract; and
- d) personal injury or death.

Policies and certificates for insurance shall be delivered by the Contractor to the Engineer or his nominee for approval before the start date. All such insurances shall provide for compensation to be payable in the types and proportions of currencies required to rectify the loss or damage incurred.

If the Contractor does not provide any of the policies and certificates required, the

Employer may effect the insurance which the Contractor should have provided and recover the premiums the Employer has paid from any payments due to the Contractor or, if no payment is due, the payment of the premiums shall be a debt due. Alterations to the terms of insurance shall not be made without the approval of the Engineer or his nominee. Both parties shall comply with all conditions of the insurance policies.

**14 Site Investigation Reports**

1.1 The Contractor, in preparing the Bid, shall rely on the Site Investigation Report referred to in the Contract Data, supplemented by any information available to the Bidder.

**15. Queries about the Contract Data**

The Engineer or his nominee will clarify queries on the Contract Data.

**16 Contractor to Construct the Works**

The Contractor shall construct and install the works in accordance with the Specification and Drawings.

The Contractor shall execute the whole and every part of the work in the most substantial and workmanlike manner both as regards materials and otherwise in every respect in strict accordance with the Specifications. The Contractor shall also conform exactly, fully and faithfully to the design, drawings and instructions in writing in respect of the work signed by the Engineer or his nominee and the Contractor shall be furnished free of charge one copy of the contract documents together with specifications, designs, drawings and instructions as are not included in the Specifications specified in Contract Data or in any Bureau of Indian Standard or any other published standard or code or, Schedule of Rates or any other printed publication referred to elsewhere in the Contract.

The Contractor shall comply with the provisions of the contract and with the care and diligence execute and maintain the works and provide all labour and materials, tools and plants including for measurements and supervision of all works, structural plans and other things of temporary or permanent nature required for such execution and maintenance in so far as the necessity for providing these, is specified or is reasonably inferred from the contract. The Contractor shall take full responsibility for adequacy, suitability and safety of all the works and methods of construction.

**17 The Works to be Completed by the Intended Completion Date**

The Contractor may commence execution of the works on the Start Date and shall carry out the works in accordance with the program submitted by the Contractor as updated with the approval of the Engineer or his nominee, and complete them by the Intended Completion Date.

**18 Approval by the Engineer or his nominee**

The Contractor shall submit Specifications and Drawings showing the proposed Temporary Works or Permanent Works, in the case of Contractor's design to the Engineer or his nominee, who is to approve them if they comply with the specifications and Drawings.

The Contractor shall be responsible for design of Temporary Works.

The Engineer or his nominee's Approval shall not alter the Contractor's responsibility for design of the Temporary Works.

All Drawings prepared by the Contractor for the execution of the temporary works, are subject to prior approval by the Engineer or his nominee before their use.

**19 Safety**

The Contractor shall be responsible for the safety of all activities on the Site.

**20 Discoveries**

Anything of historical or other interest or of significant value unexpectedly discovered

on the Site is the property of the Employer. The Contractor is to notify the Engineer or his nominee of such discoveries and carry out the Engineer or his nominee's instructions for dealing with them.

**21 Possession of the Site**

The Employer shall give possession of all parts of the Site to the Contractor, free from encumbrances. If possession of a part is not given by the date stated in the Contract Data the Employer is deemed to have delayed the start of the relevant activities and this will be a Compensation Event.

**22 Access to the Site**

The Contractor shall allow the Engineer or his nominee and any person authorised by the Engineer or his nominee access to the Site or to any place where work in connection with the Contract is being carried out or is intended to be carried out and to any place where materials or plant are being manufactured, fabricated and /or assembled for the works.

**23 Instructions**

The Contractor shall carry out all instructions of the Engineer or his nominee which comply with the applicable laws where the Site is located.

**24 Disputes**

If the Contractor believes that a decision taken by the Engineer or his nominee was either outside the authority given to the Engineer or his nominee by the Contract or that the decision was wrongly taken, the decision shall be referred to the Employer within 28 days of the notification of the Engineer or his nominee's decision.

**25. Settlement of Disputes & Arbitration**

**General**

Except where otherwise provided in the contract all questions and disputes relating to the meaning of the specifications, design, drawings and instructions here-in before mentioned and as to the quality of workmanship or materials used on the work or as to any other question, claim, right, matter or thing whatsoever in any way arising out of or relating to the contract, designs, drawings, specifications, estimates, instructions, orders or these conditions or otherwise concerning the works or the execution or failure to execute the same whether arising during the progress of the work or after the cancellation, termination, completion or abandonment thereof shall be dealt with as mentioned hereinafter:-

If the Contractor considers any work demanded of him to be outside the requirements of the contract, or disputes any drawings, record or decision given in writing by the Engineer on any matter in connection with or arising out of the contract or carrying out of the work, to be unacceptable, he shall promptly within 15 days request the Engineer in writing for written instruction or decision. Thereupon, the Engineer shall give his written instructions or decision within a period of one month from the receipt of the Contractor's letter.

If the Engineer fails to give his instructions or decision in writing within the aforesaid period or if the Contractor is dissatisfied with the instructions or decision of the Engineer, the Contractor may, within 15 days of the receipt of Engineer's decision, appeal to the Chairman who shall afford an opportunity to the Contractor to be heard, if the latter so desires, and to offer evidence in support of his appeal. The Chairman shall give his decision within 30 days of receipt of Contractor's appeal. If the Contractor is dissatisfied with this decision then:

- a) The Dispute in respect of contract of value upto Rs. 1crore shall not be referred for

adjudication through arbitration and.

- b) If the value of the contract is exceeding Rs. 1 crore and upto Rs.5 crores,
- (i) The Dispute shall be resolved through arbitration by a sole arbitrator appointed by the Chairman of Cochin Port Authority :
- (ii) The Contractor shall within a period of 30 days from receipt of the decision of the Chairman, give notice to the Chairman for appointment of arbitrator, failing which, the said decision shall be final, binding and conclusive and not referable to adjudication by the arbitrator.

If the arbitrator so appointed is unable or unwilling to act or resigns his appointment or vacates his office due to any reason whatsoever another sole arbitrator shall be appointed in the manner aforesaid. Such person shall be entitled to proceed with the reference from the stage at which it was left by his predecessor.

- c) If the value of the Contract is above Rs. 5 crores, the Contractor shall within 30 days of receipt of the decision of the Chairman, appoint an arbitrator and give notice to the Chairman and the dispute shall be resolved through Arbitral Tribunal as detailed below:

The Arbitral Tribunal shall be a panel of three arbitrators, one to be appointed by each Party and the third to be appointed by the two Arbitrators appointed by the Parties. A Party requiring Arbitration shall appoint an Arbitrator in writing, inform the other Party about such appointment and call upon the other Party to appoint its Arbitrator. If the other Party fails to appoint its Arbitrator, the Party appointing Arbitrator shall take steps in accordance with Arbitration and Conciliation Act, 1996 or any statutory modifications or reenactment thereof

- d) In case of the dispute or difference is relating to interpretation and application of the provisions of commercial contract between Central Public Sector Enterprises (CPSE), Port Authority inter se or CPSE and Government Department shall be referred by either party for arbitration to the Permanent Machinery of Arbitrators in the Department of Public Enterprises through the Secretary to the Government of Public Enterprises as per the guidelines issued by Department of Public Enterprises OM No.4 (1) 2011- DPE (PMA)

– GL dtd. 12.06.2013 or any statutory amendment thereof.

It is a term of this contract that the party invoking arbitration shall give a list of disputes with amounts claimed in respect of each such dispute along with the notice for appointment of arbitrator and giving reference to the rejection by the Chairman of the appeal.

It is also a term of this contract that no person other than person / persons appointed as aforesaid should act as arbitrator / arbitrators and if for any reason that is not possible, the matter shall not be referred to arbitration at all.

It is also a term of this contract that if the Contractor does not make any demand for appointment of arbitrator in respect of any claims in writing as aforesaid within 120 days of receiving the intimation from the Engineer that the final bill is ready for payment, the claim of the Contractor shall be deemed to have been waived and absolutely barred and the Employer or his authorized representative shall be discharged and released of all liabilities under the contract in respect of these claims. The arbitration shall be conducted in accordance with the provisions of the Arbitration and Conciliation Act, 1996 (26 of 1996) or any statutory modifications or reenactment thereof and the rules made there under and for the time being in force shall apply to the arbitration proceeding under this clause.

It is also a term of this contract that the Arbitrator / Arbitral Tribunal shall

adjudicate only on such disputes as are referred to him/them and give separate award against each dispute and claim referred and in all cases where the total amount of the claims by any party exceeds Rs. 1,00,000/- the arbitrator shall give reasons for the award.

It is also a term of the contract that if any fees are payable to the arbitrator these shall be paid equally by both the parties.

It is also a term of the contract that the arbitrator/arbitrators shall be deemed to have entered on the reference on the date he / they issues notice to both the parties calling them to submit their statement of claims and counter statement of claims. The venue of the arbitration shall be at Cochin. The fees, if any, of the arbitrator shall, if required to be paid before the award is made and published, be paid half and half by each of the parties. The cost of the reference and of the award (including the fees, if any, of the arbitrator) shall be in the discretion of the arbitrator who may direct to any party by whom and in what manner, such costs or any part thereof shall be paid and fix or settle the amount of costs to be so paid.¶

**26. Computerised Measurement Book**

Engineer or his nominee shall, except as otherwise provided, ascertain and determine by measurement, the value of work done in accordance with the contract.

All measurement of all items having financial value shall be entered by the Contractor and compiled in the shape of the Computerised Measurement Book having pages of A-4size as per the format of the department so that a complete record is obtained of all the items of works performed under the Contract.

All such measurements and levels recorded by the Contractor or his authorized representative from time to time, during the progress of the work, shall be got checked by the Contractor from the Engineer or his authorized representative as per interval or program fixed in consultation with Engineer or his authorized representative. After the necessary corrections made by the Engineer or his nominee, the measurement sheets shall be returned to the Contractor for incorporating the corrections and for resubmission to the Engineer for the dated signatures by the Engineer or his nominee and the Contractor or their representatives in token of their acceptance.

Whenever bill is due for payment, the Contractor would initially submit draft computerized measurement sheets and these measurements would be got checked/test checked from the Engineer- and/or his authorized representative. The Contractor will, thereafter, incorporate such changes as may be done during these checks/test checks in his draft computerized measurements, and submit to the department a computerized measurement book, duly bound, and with its pages machine numbered. The Engineer and/or his authorized representative would thereafter check this MB, and record the necessary certificates for their checks/test checks.

The final, fair, computerized measurement book given by the Contractor, duly bound, with its pages machine numbered, should be 100% correct, and no cutting or over-writing in the measurements would thereafter be allowed. If at all any error is noticed, the Contractor shall have to submit a fresh computerized MB with its pages duly machine numbered and bound, after getting the earlier MB cancelled by the department.

Thereafter, the MB shall be taken in the Divisional Office records, and allotted a number as per the Register of Computerised MBs. This should be done before the corresponding bill is submitted to the Division Office for payment. The Contractor shall submit two spare copies of such computerized MB's for the purpose of reference and record by the various officers of the department.

The Contractor shall also submit to the department separately his computerized Abstract of Cost and the bill based on these measurements, duly bound, and its pages

machine numbered along with two spare copies of the bill. Thereafter, this bill will be processed by the Division Office and allotted a number as per the computerized record in the same way as done for the measurement book meant for measurements.

The Contractor shall, without extra charge, provide all assistance with every appliance, labour and other things necessary for measurements and recording levels.

Except where any general or detailed description of the work expressly shows to the contrary, measurements shall be taken in accordance with the procedure set forth in the Specifications notwithstanding any provision in the relevant Standard Method of measurement or any general or local custom. In the case of items which are not covered by specifications, measurements shall be taken in accordance with the relevant standard method of measurement issued by the Bureau of Indian Standards and if for any item no such standard is available then a mutually agreed method shall be followed. The Contractor shall give not less than seven days' notice to the Engineer or his authorised representative in charge of the work before covering up or otherwise placing beyond the reach of measurement any work in order that the same may be measured and correct dimensions thereof be taken before the same is covered up or placed beyond the reach of measurement and shall not cover up and place beyond reach of measurement any work without consent in writing of the Engineer or his authorised representative in charge of the work who shall within the aforesaid period of seven days inspect the work, and if any work shall be covered up or placed beyond the reach of measurements without such notice having been given or the Engineer's consent being obtained in writing the same shall be uncovered at the Contractor's expense, or in default thereof no payment or allowance shall be made for such work or the materials with which the same was executed.

Engineer or his authorised representative may cause either themselves or through another officer of the department to check the measurements recorded jointly or otherwise as aforesaid and all provisions stipulated herein above shall be applicable to such checking of measurements or levels.

It is also a term of this Contract that recording of measurements of any item of work in the measurement book and/or its payment in the interim, on account or final bill shall not be considered as conclusive evidence as to the sufficiency of any work or material to which it relates nor shall it relieve the Contractor from liabilities from any over measurement or defects noticed till completion of the Defects Liability Period.

**B. Time Control**

**27. Program**

Within the time stated in the Contract Data the Contractor shall submit to the Engineer or his nominee for approval a Program showing the general methods, arrangements, order, and timing for all the activities in the works along with monthly cash flow forecast.

An update of the Program shall be a program showing the actual progress achieved on each activity and the effect of the progress achieved on the timing of the remaining work including any changes to the sequence of the activities. The Contractor shall submit to the Engineer on the first day of each week or such longer period as the Engineer may from time to time direct, a progress report in an approved form showing up-to-date total progress, progress achieved against planned progress, during the previous week and progress forecast for the following week for all important items in each section or portion of the Works, in relation with the approved Program.

The Contractor shall submit to the Engineer or his nominee, for approval an updated Program at intervals no longer than the period stated in the Contract

Data. If the Contractor does not submit an updated Program within this period, the Engineer or his nominee may withhold the amount stated in the Contract Data from the next payment certificate and continue to withhold this amount until the next payment after the date on which the overdue Program has been submitted.

**28. Revised Program**

The Engineer or his nominee's approval of the Program shall not alter the Contractor's obligations. The Contractor may revise the Program and submit it to the Engineer or his nominee again at any time for approval. A revised Program is to show the effect of Variations and Compensation Events.

**29. Extension of the Intended Completion Date**

The Engineer or his nominee shall extend the Intended Completion Date if a Compensation Event occurs or a Variation is issued which makes it impossible for Completion to be achieved by the Intended Completion Date without the Contractor taking steps to accelerate the remaining work and which would cause the Contractor to incur additional cost.

The Engineer or his nominee shall decide whether and by how much to extend the Intended Completion Date within 21 days of the Contractor asking the Engineer or his nominee for a decision upon the effect of a Compensation Event or Variation or any other events causing delay, beyond the control of the Contractor and submitting full supporting information. If the Contractor has failed to give early warning of a delay or has failed to cooperate in dealing with a delay, the delay by this failure shall not be considered in assessing the new Intended Completion Date.

Such Request for extension of time, to be eligible for consideration, shall be made by Contractor in writing within fourteen days of the happening of the event causing delay on the prescribed form. The Contractor may also, if practicable, indicate in such a request the period for which extension is desired.

**30. Delays Ordered by the Engineer or his nominee**

The Engineer or his nominee may instruct the Contractor to delay the start or progress of any activity within the Works.

**31. Management Meetings**

Either the Engineer or his nominee or the Contractor may require the other to attend a management meeting. The business of a management meeting shall be to review the plans for remaining work and to deal with matters raised in accordance with the early warning procedure.

The Engineer or his nominee shall record the business of management meetings and is to provide copies of his record to those attending the meeting and to the Employer. The responsibility of the parties for actions to be taken is to be decided by the Engineer or his nominee either at the management meeting or after the management meeting and stated in writing to all who attended the meeting.

**32. Early Warning**

The Contractor is to warn the Engineer or his nominee at the earliest opportunity of specific likely future events or circumstances that may adversely affect the quality of the work, increase the Contract Price or delay the execution of works. The Engineer or his nominee may require the Contractor to provide an estimate of the expected effect of the event or circumstance on the Contract Price and Completion Date. The estimate is to be provided by the Contractor as soon as reasonably possible.

The Contractor shall cooperate with the Engineer or his nominee in making and

considering proposals for how the effect of such an event or circumstance can be avoided or reduced by anyone involved in the work and in carrying out any resulting instruction of the Engineer or his nominee.

The Contractor shall immediately give notice in writing to the Engineer or his nominee upon happening of any event as detailed below if the work is delayed by:

- i) Force majeure, or
- ii) Abnormally bad weather, or
- iii) Serious loss or damage by fire, or
- iv) Civil commotion, local commotion of workmen, strike or lockout, affecting any of the trades employed on the work, or
- v) Delay on the part of other Contractors or tradesmen engaged by Engineer in executing work not forming part of the Contract, or
- vi) Any other cause which, in the absolute discretion of Engineer, is beyond the Contractor's control.

**33. Force Majeure**

"Force Majeure" means an exceptional event or circumstance:

- (a) Which is beyond a Party's control,
- (b) Which such Party could not reasonably have provided against before entering into the Contract,
- (c) Which, having arisen, such Party could not reasonably have avoided or overcome, and
- (d) Which is not substantially attributable to the other Party.

Force Majeure may include, but is not limited to, exceptional events or circumstances of the kind listed below, so long as conditions (a) to (d) above are satisfied:

- (i) War and hostilities (whether war be declared or not), invasion, act of foreign enemies;
- (ii) Rebellion, revolution, insurrection, or military or usurped power, or civil war;
- (iii) Ionizing radiations, or contamination by radioactivity from any nuclear fuel, or from any nuclear waste, from the combustion of nuclear fuel, radioactive toxic explosive or other hazardous properties of any explosive nuclear assembly or nuclear component thereof;
- (iv) Pressure waves caused by aircraft or other aerial devices travelling at sonic or supersonic speeds; and
- (v) Riot, commotion or disorder, unless solely restricted to the employees of the Contractor or of his Sub Contractors and arising from the conduct of the Works;
- (vi) Floods, tornadoes, earthquakes and landslides.

**C. Quality Control**

**34. Identify Defects**

The Engineer or his nominee shall check the Contractor's work and notify the Contractor of any Defects that are found. Such checking shall not affect the Contractor's responsibilities. The Engineer or his nominee may instruct the Contractor to search for a Defect and to uncover and test any work that the Engineer or his nominee considers may have a Defect.

**35. Tests**

If the Engineer or his nominee instructs the Contractor to carry out a test not specified in the Specification to check whether any work has a Defect and if the test shows that it has defect, the Contractor shall pay for the test and any samples. If there is no Defect the test shall be a Compensation Event.

**36. Defect Liability**

The Engineer or his nominee shall give notice to the Contractor of any Defects

before the end of the Defects Liability Period, which begins at Completion and is defined in the Contract Data. The Defects Liability Period shall be extended for as long as Defects remain to be corrected.

Every time notice of a Defect is given, the Contractor shall correct the notified defect within the length of time specified by the Engineer or his nominee's notice. To the intent that the works shall, at or as soon as practicable after the expiration of the Defects Liability Period, be delivered to the Employer in the condition required by the Contract, fair wear and tear excepted, to the satisfaction of the Engineer, the Contractor shall :

- (a) Complete the work, if any, outstanding on the date stated in the Taking-Over Certificate within the date to be intimated by the Engineer and
- (b) Execute all such work of amendment, reconstruction, and remedying defects, shrinkages or other faults as the Engineer may, during the Defects Liability Period or within 14 days after its expiration, as a result of an inspection made by or on behalf of the Engineer prior to its expiration, instruct the Contractor to execute.

#### **Cost of Remedying Defects**

All work referred to in Sub-Clause 36.2 shall be executed by the Contractor at his own cost if the necessity thereof is, in the opinion of the Engineer, due to:

- (a) The use of materials, Plant or workmanship not in accordance with the Contract, or
- (b) Where the Contractor is responsible for the design of part of the Permanent Works, any fault in such design, or the neglect or failure on the part of the Contractor to comply with any obligation, expressed or implied, on the Contractor's part under the Contract.

#### **Defects Liability Certificate**

The Contract shall not be considered as completed until a Defects Liability Certificate shall have been signed by the Engineer and delivered to the Employer, with a copy to the Contractor, stating the date on which the Contractor shall have completed his obligations to execute and complete the Works and remedy any defects therein to the Engineer's satisfaction. The Defects Liability Certificate shall be given by the Engineer within 28 days after the expiration of the Defects Liability Period, or, if different defects liability periods shall become applicable to different Sections or parts of the Permanent Works, the expiration of the latest such period, or as soon thereafter as any works instructed, pursuant to Clauses 36, have been completed to the satisfaction of the Engineer.

#### **Unfulfilled Obligations**

Notwithstanding the issue of the Defects Liability Certificate the Contractor and the Employer shall remain liable for the fulfillment of any obligation incurred under the provisions of the Contract prior to the issue of the Defects Liability Certificate which remains unperformed at the time such Defects Liability Certificate is issued and, for the purposes of determining the nature and extent of any such obligation, the Contract shall be deemed to remain in force between the parties to the Contract.

#### **Uncorrected Defects.**

If the Contractor has not corrected a Defect within the time specified in the Engineer's or his nominee's notice the Engineer or his nominee will assess the cost of having the Defect corrected, and the Contractor will pay this amount.

### **D. Cost Control**

#### **37. Bill of Quantities**

The Bill of Quantities shall contain items for the construction, supply, installation, testing and commissioning work to be done by the Contractor.

The Bill of Quantities is used to calculate the Contract Price. The Contractor is paid for the quantity of the work done at the rate in the Bill of Quantities for

each item.

**38. Changes in the Quantities**

If the final quantity of the work done differs from the quantity in the Bill of Quantities for the particular item by more than 25 % provided the change exceeds (+)10% of initial Contract Price, the Engineer or his nominee shall adjust the rate(s), to allow for the change.

The Engineer or his nominee shall not adjust rates for changes in quantities if thereby the Initial Contract Price is exceeded by more than 10% except with the prior approval of the Employer.

If requested by the Engineer or his nominee where the quoted rate (s) of any item(s) is abnormally high, the Contractor shall provide the Engineer or his nominee with a detailed cost breakdown of such rate in the Bill of Quantities.

**39. Variations**

The Engineer shall make any Variation of the form, quality or quantity of the Works or any part thereof that may, in his opinion, be necessary and for that purpose, or if for any other reason it shall, in his opinion, be appropriate, he shall have the authority to instruct the Contractor to do and the Contractor shall do any of the following:

- (a) increase or decrease the quantity of any work included in the Contract,
- (b) omit any such work,
- (c) change the character or quality or kind of any such work,
- (d) change the levels, lines, position and dimension of any part of the Works,
- (e) execute additional work of any kind necessary for the completion of the Works,
- (f) change any specified sequence or timing of construction of any part of the Works.

No such Variation shall in any way vitiate or invalidate the Contract, by the effect, if any, of all such Variations shall be valued in accordance with Clause 40. Provided that where the issue of an instruction to vary the works is necessitated by some default of or breach of contract by the Contractor or for which he is responsible, any additional cost attributable to such default shall be borne by the Contractor. All Variations shall be included in updated Programs produced by the Contractor.

**Instructions for Variations**

The Contractor shall not make any such Variation without an instruction of the Engineer. Provided that no instruction shall be required for increase or decrease in the quantity of any work where such increase or decrease is not the result of an instruction given under this clause, but is the result of the quantities exceeding or being less than those stated in the Bill of Quantities.

**40. Payments for Variations**

Variation permitted shall not exceed (+) 25% in quantity of each individual item, and (+)10% of the total contract price. Within 14 days of the date of instruction for executing varied work, extra work or substitution, and before the commencement of such work, notice shall be given either (a) by the Contractor to the Employer of his intention to claim extra payment or a varied rate or price, or (b) by the Employer to the Contractor of his intention to vary rate or price.

For items not existing in the Bill of Quantities or substitution to items in the Bill of Quantities, rate payable should be determined by methods given below and in the order given below:

- i) Rates and prices derived from the rate of similar items in Contract.
- ii) Rates and prices in the Schedule of Rates applicable to the Contract plus Ruling percentage.
- iii) Market rates of materials and labor, hire charges of plant and machinery used, plus

10% for overheads and profits of Contractor.

For items in the Bill of Quantities but where quantities have increased beyond the variation limits, the rate payable for quantity in excess of the quantity in the Bill of Quantity plus the permissible variation shall be as determined by methods given below:

- i) Rates and prices in the Schedule of Rates applicable to the Contract plus Ruling percentage.
- ii) Market rates of material and labor, hire charges of plant and machinery used plus 10% for overheads and profits of Contractor.

whichever is lower, but not less than the rate in the Bill of Quantities

If there is delay in the Employer and the Contractor coming to an agreement on the rate of an extra item, rates as proposed by the Employer shall be payable provisionally till such time as the rates are finally determined or till date mutually agreed.

If the Engineer or his nominee decides that the urgency of varying the work prevent a quotation being given and considers not delaying the work, no quotation shall be given and the Variation shall be treated as a Compensation Event.

**41. Cash flow forecasts**

When the Program is updated, the Contractor is to provide the Engineer or his nominee with an updated cash flow forecast.

**42. Payment Certificates**

The Contractor shall submit to the Engineer or his nominee monthly statements of the estimated value of the work completed less the cumulative amount certified previously.

The Engineer or his nominee shall check the Contractors' monthly statement within 14 days and certify the amount to be paid to the Contractor after taking into account any credit or debit for the month in question in respect of materials for the works in the relevant amounts and under conditions set forth in sub-clause 51.6 of the Contract Data (Secured Advance).

The value of work executed shall be determined by the Engineer or his nominee. The value of work executed shall comprise the value of the quantities of the items in the Bill of quantities completed.

The value of work executed shall include the valuation of variations and Compensation Events.

The Engineer or his nominee may exclude any item certified in a previous certificate or reduce the proportion of any item previously certified in any certificate in the light of later information.

**43. Payments**

Bills shall be prepared and submitted by the Contractor. Joint measurements shall be taken continuously and need not be connected with billing stage. System of 4 copies of measurements, one each for Contractor, Employer and Engineer or his nominee, and signed by both Contractor and Engineer or his nominee shall be followed.

Payment of Bills for civil works shall be regulated as detailed hereunder:

Interim Bills shall be paid within 21 days of date of submission of bills in full shape by the Contractor. 75% of the bill amount shall be paid within 7 days of submission of the bill, if on request by the Contractor. Balance amount of the verified bill shall be paid within 21 days of the submission of the bill.

Final Bill shall be paid within 3 months as detailed below on issue of Taking Over Certificate by the Engineer or his nominee. The Contractor shall submit final Bill

within 30 days of issue of Taking Over Certificate. Engineer or his nominee shall check the bill within 30 days after its receipt and return the bill to Contractor for corrections, if any. The Contractor should re-submit the bill with corrections within 15 days of its return by the Engineer or his nominee. The re-submitted bill shall be checked and paid within 30 days of its receipt.

Payment for Electrical and Mechanical works shall be regulated as detailed below:

The Contractor shall be entitled upon certificates of the Engineer or his nominee to payments in accordance with the following provisions:

- 1) **For supply portion :** 75% of the value, as certified by the Engineer or his nominee, of the materials from time to time delivered on the site.  
Balance 25% after completing the work in all respects, commissioning and handing over the installation to the Employer to the satisfaction of the Engineer and his nominee and his certification.

2) **For erection portion :**

- i) 85% of the value as certified by the Engineer or his nominee, of the installation portion on completion of the erection work under contract, for which payments are claimed.
- ii) Balance 15% along with other payments if any, after completing the work in all respects, commissioning and taking over the installation by the Employer to the satisfaction of the Engineer and his nominee and his certification.

For HT works, the work shall not be considered as completed until the installation is energized after obtaining approval certificate from Central Electrical Authority(CEA) and upon the issuance of taking over certificate by Engineer or his nominee. The final payment shall be made only after taking over the installation by the Employer.

All the interim payments shall be regarded as payment by way of advances against final payment only and shall not preclude the requiring of bad, unsound and imperfect or unskilled work to be rejected, removed, taken away and reconstructed or re-erected. Any certificate given by the Engineer or his nominee relating to the work done or materials delivered forming part of such payment, may be modified or corrected by any subsequent such certificate(s) or by the final certificate and shall not by itself be conclusive evidence that any work or materials to which it relates is/are in accordance with the contract and specifications. Any such interim payment, or any part thereof shall not in any respect conclude, determine or affect in any way powers of the Engineer- or his nominee-charge under the contract or any of such payments be treated as final settlement and adjustment of accounts or in any way vary or affect the contract.

Pending consideration of extension of date of completion interim payments shall continue to be made as herein provided, without prejudice to the right of the department to take action under the terms of this contract for delay in the completion of work, if the extension of date of completion is not granted by the competent authority.

No further claims shall be made by the Contractor after submission of the final bill and these shall be deemed to have been waived and extinguished.

If an amount certified is increased in a later certificate as a result of an award by the Arbitrator, the Contractor shall be paid interest upon the delayed payment as set out in the award. Interest shall be calculated from the date upon which the increased amount would have been certified in the absence of dispute.

Items of the Works for which no rate or price has been entered in will not be paid for by the Employer and shall be deemed covered by other rates and

prices in the Contract.

All payments to the Contractor under the contract shall unless otherwise stated elsewhere be made to the Contractor in Indian currency through e- payments through designated Bank.

**44 Compensation Events**

The following mutually agreed Compensation Events unless they are caused by the Contractor would be applicable:

- (a) The Employer does not give access to a part of the Site by the Site Possession Date stated in the Contract Data.
- (b) The Employer modifies the schedule of other Contractors in a way which affects the work of the Contractor under the contract.
- (c) The Engineer or his nominee orders a delay or does not issue drawings, specifications or instructions required for execution of works on time.
- (d) The Engineer or his nominee instructs the Contractor to uncover or to carry out additional tests upon work which is then found to have no Defects.
- (e) Ground conditions are substantially more adverse than could reasonably have been assumed before issuance of Letter of Acceptance from the information issued to Bidders (including the Site Investigation Reports), from information available publicly and from a visual inspection of the site.
- (f) The Engineer or his nominee gives an instruction for dealing with an unforeseen condition, caused by the Employer, or additional work required for safety.
- (g) Other Contractors, public authorities, utilities or the Employer does not work within the dates and other constraints stated in the Contract that cause delay or extra cost to the Contractor.
- (h) The effect on the Contractor of any of the Employer's Risks.
- (i) Any other Compensation Events listed in the Contract Data or mentioned in the contract.

Whenever any compensation event occurs, the Contractor will notify the Employer, within 14 days and provide a forecast cost of the compensation event.

If a Compensation Event would cause additional cost or would prevent the work being completed in the Intended Completion Date, the Contract Price shall be increased and/or the Intended Completion Date shall be extended. The Engineer or his nominee shall decide whether and by how much the Contract Price shall be increased and whether and by how much the Intended Completion Date shall be extended.

As soon as information demonstrating the effect of each Compensation Event upon the Contractor's forecast has been provided by the Contractor, it is to be assessed by the Engineer or his nominee and the Contract Price shall be adjusted accordingly. If the Contractor's forecast is deemed unreasonable the Engineer or his nominee shall adjust the Contract Price based on Engineer or his nominee's own forecast. The Engineer or his nominee will assume that the Contractor will react competently and promptly to the event.

**45. Rates for items to be inclusive of Taxes**

The rates quoted by the Contractor shall be deemed to be inclusive of the sales tax and other taxes, but excluding service tax that the Contractor will have to pay for the performance of this Contract. The Employer will perform such duties in regard to the deduction of such taxes at sources as per applicable law. Any new Taxes, levies, duties imposed after signing the Contract shall be reimbursed by the Employer on production of documentary evidence.

Service Tax shall be claimed by the Contractor in the invoice except for those services which are covered under Negative list of Services under section 66D of the Finance Act and Mega Exemption Notification No 25/2012-ST dated 20.06.2012. The rate of Service Tax shall be as per the provisions of Point of Taxation Rules, 2011 and value on which service tax to be applied shall be as per the provisions of Service Tax (Determination of Valuation Rules), 2006. Where the contractor is an individual, HUF, Partnership firm or Association of Person, Service Tax shall be claimed under Reverse Charge Mechanism.

**46. Currencies**

All payments shall be made in Indian Rupees unless specifically mentioned.

**47 Price Adjustment.**

No price adjustment shall be made for works except for the provisions under clause

47.1.A herein under and clause 47.2 for any subsequent change in legislation.

47.1.A For Civil contract works, with intended completion period of the contract more than 12 months, Price adjustment shall be made for the variation in price of materials such as cement, reinforcement steel, structural steel, bitumen and bitumen emulsion. Compensation for variation in cost of the materials shall be regulated as described below subject to the condition that such compensation for variation in prices shall be only for the work done during the stipulated period of the contract including such period for which the validity of the contract is extended.

The rates quoted for the items in the Schedule of Quantities shall be based on the Base rates of the materials provided in the Contract Data and these base rates are applicable at the Supplier's local delivery point and shall not include cost of loading to Contractor's vehicle, transporting to work site and unloading and stacking at work site. During execution and actual procurement by the Contractor, increase or decrease in the cost of materials over the Base rate (which results in an increase or decrease of cost to the Contractor in carrying out the works) shall form an addition or reduction as the case may be to or from the contract price and shall be paid to or allowed by the Contractor accordingly, provided that such increase or decrease shall relate only to the quantities of material which the Engineer is satisfied as reasonably required for the works. While considering the reasonable requirement of the materials for the work, allowance towards wastage/unusable cutting bits shall be permitted as provided in the Contract Data. The prices of materials considered for regulating the payment as aforesaid shall be the price charged by the suppliers approved by the Engineer at the supplier's local delivery point and this shall not include the cost of loading to the Contractor's vehicle, transporting to the work site and unloading and stacking at work site

**Subsequent Legislation**

If, after 28 (Twenty eight) days prior to the last date for submission of tenders for the contract, there occur changes to any National or State Statute, Ordinance or Decree or other Law or any regulation or bye law of any local or other duly constituted authority or introduction of any such state statute, Ordinance, Decree, Law, regulation or bye law which causes additional or reduced cost to the Contractor in execution of the contract, such additional or reduced cost shall, after due consultation with the Employer and the Contractor be determined by the Engineer or his nominee and shall be added to or deducted from the contract price and the Engineer or his nominee shall notify the Contractor accordingly with a copy to the Employer.

**48 Retention**

The Employer shall retain from each payment due to the Contractor the proportion stated in the Contract Data until Completion of the whole of the Works.

For civil works, Retention Money shall be deducted at 5% of the gross

amount of the bill from the first Running Account bill onwards till the recovered sum amounts to 5% of the contract value or the value of the work done whichever is higher. Retention money shall be refunded to the Contractor within 14days from the date of payment of final bill. No retention money shall be deducted for Electrical and Mechanical works.

**49 Liquidated Damages**

49A In case of delay in completion of the contract, liquidated damages (L.D) may be levied at the rate of half per cent (½%) of the contract price per week of delay, subject to a maximum of 10 per cent of the contract price. The amount of Liquidated damages can be adjusted or set-off against any sum payable to the Contractor.

49A(i) The Employer, if satisfied, that the works can be completed by the Contractor within a reasonable time after the specified time for completion, may allow further extension of time at its discretion with or without the levy of L.D. In the event of extension granted being with L.D, the Employer will be entitled without prejudice to any other right or remedy available in that behalf, to recover from the Contractor as agreed damages equivalent to half per cent (½%) of the contract value of the works for each week or part of the week subject to the ceiling defined in sub-Clause 49 A.

49A(ii) The Employer, if not satisfied that the works can be completed by the Contractor, and in the event of failure on the part of the Contractor to complete work within further extension of time allowed as aforesaid, shall be entitled, without prejudice to any other right, or remedy available in that behalf, to rescind the contract.

49A(iii) The Employer, if not satisfied with the progress of the contract and in the event of failure of the Contractor to recoup the delays in the mutually agreed time frame, shall be entitled to terminate the contract.

49A(iv) In the event of such termination of the contract as described in clauses 49A(ii) or 49A(iii) or both the Employer shall be entitled to recover L.D. upto ten per cent (10%) of the contract value and forfeit the security deposit made by the Contractor besides getting the work completed by other means at the risk and cost of the Contractor.

**49B Reduction of Liquidated Damages**

If, before the Time for Completion of the whole of the Works or, if applicable, any Section, Taking Over Certificate has been issued for any part of the Works or of a Section, the liquidated damages for delay in completion of the remainder of the Works or of that section shall, for any period of delay after the date stated in such Taking Over Certificate, and in the absence of alternative provisions in the Contract, be reduced in the proportion which the value of the part so certified bears to the value of the whole of the Works or Section, as applicable. The provisions of this Sub-Clause shall only apply to the rate of liquidated damages and shall not affect the limit thereof.

**50 Nominated Sub Contractors**

All specialists, merchants, tradesmen and others executing any work or supplying any good, materials, Plant or services for which provisional Sums are included in the Contract, who may have been or be nominated or selected or approved by the Employer or the Engineer, and all persons to whom by virtue of the provisions of the Contract, the Contractor is required to subcontract shall, in the execution of such work or the supply of such goods, materials, Plant or services, be deemed to be Sub Contractors to the Contractor and are referred to in this Contract as –Nominated Sub Contractors|.

**51 Advance payment**

The Employer shall make the following advance payments (as admissible in the contract data) if requested by the Contractor in writing:

Mobilisation Advance shall be paid upto 5% of Contract price, payable in two equal installments. The first installment shall be paid after mobilisation has started and next

installment shall be paid after satisfactory utilisation of earlier advance for which, the Contractor shall furnish proof of the satisfactory utilization of the amount.

Construction/ installation equipment Advance shall be paid upto 5% of Contract price, limited to 90% of assessed cost of machinery. Equipment advance will be paid in two or more installments. First installment shall be paid after Construction Equipment has arrived at the site and next installment shall be paid after satisfactory utilisation of earlier advance (s).

Mobilisation Advance and Construction Equipment Advance shall be paid at 14% interest rate and against Bank Guarantee for Mobilisation Advance and against hypothecation of Construction Equipment to the Employer.

Recovery of Mobilisation and Construction Equipment advance will start when 15% of the work is executed and recovery of total advance should be completed by the time 80% of the original Contract work is executed.

The above advance payments shall be admissible only for the works where estimated cost put to tender is more than Rs. 5.0 crores.

#### **Secured Advance**

The Engineer or his nominee shall make advance payment in respect of materials and plant brought to site but not yet incorporated and installed in the Works in accordance with conditions stipulated in the Contract Data.

75% of cost of materials and plant brought to site for incorporation into the works only shall be paid as Secured Advance. Materials which are of perishable nature should be adequately insured.

The Contractor, on signing an indenture in the form to be specified by the Engineer, shall be entitled to be paid during the progress of the execution of the work upto 75% of the assessed value of any materials which are in the opinion of the Engineer non-perishable, non-fragile and non-combustible and are in accordance with the contract and which have been brought on the site in connection therewith and are adequately stored and/or protected against damage by weather or other causes but which have not at the time of advance been incorporated in the works. When materials on account of which an advance has been made under this sub-clause are incorporated in the work the amount of such advance shall be recovered/deducted from the next payment made under any of the clause or clauses of this contract.

Such secured advance shall also be payable on other items of perishable nature, fragile and combustible with the approval of the Engineer provided the Contractor provides a comprehensive insurance cover for the full cost of such materials. The decision of the Engineer shall be final and binding on the Contractor in this matter. No secured advance, shall however, be paid on high-risk materials such as ordinary glass, sand, petrol, diesel etc.

52

#### **Securities**

Security Deposit (SD) shall be at 10% of the contract value or value of the work done whichever is higher and it shall consist of two parts:

- a) Performance Security to be submitted at award of the work
  - b) Retention Money to be recovered from Running Bills as detailed in Clause 48 above.
- The total amount thus deposited towards SD will be retained as security for the due and proper fulfillment of the contract and will not carry any interest. Such deposit shall be forfeited on failure to perform or non-fulfillment by the Contractor of the terms and conditions of the contract.

**Performance Security** shall be as below:

- a) For civil works : 5% of the Contract value
- b) For all Electrical and Mechanical works : 10% of the Contract value

The Performance Security shall be provided by the Contractor to the Employer not later than 21 days for domestic bids and 28 days for international bids from the date of letter of acceptance and shall be furnished in one of the following forms:

- i) Banker's Cheque/Demand Draft/Pay Order of a Scheduled Bank.
- ii) An irrevocable Bank Guarantee(BG) enforceable and encashable at Cochin, drawn from any scheduled bank operating in India as per the proforma.

The BG furnished towards the Performance Security shall be valid for a period until a date 30days from the day of expiry of the defect liability period stipulated as per the terms of the contract.

Unless performance Security is furnished within the period as specified in clause 52.3 above or such extension of that period as may be permitted by the Engineer in writing, the Earnest Money will be liable to forfeiture and the contract to cancellation. Performance Security will be released / refunded to the Contractor not later than 30 days from the date of completion of Defect Liability / warranty period of the work.

**53 Removal of Craft or Plant which has sunk**

The Contractor shall forthwith and with dispatch at his own cost raise and remove any craft or plant (floating or otherwise) belonging to him or to any sub-Contractor employed by him (including also any plant which is held by the Contractor or any sub-Contractor under agreement for hire or hire-purchase) which may be sunk in the course of the construction completion or maintenance of the Works or otherwise deal with the same as the Engineer may direct or until the same shall be raised and removed, the Contractor shall set all such buoys and display at night such lights and do all such things for the safety of navigation as may be required by the Engineer or by Employer. In the event of the Contractor not carrying out his obligation imposed upon him by this clause the Employer may provide buoy and light such sunken craft or plant and raise and remove the same (without prejudice to the right of the Employer to hold the Contractor liable under General Conditions) and the Contractor shall refund to the Employer all costs incurred in connection therewith.

**Contractor's Temporary Moorings**

Should the Contractor need, in connection with implementing the Works, to provide temporary moorings for his craft he may be allowed to do so in location and manner approved by the Engineer subject to all necessary permissions being first obtained by the Contractor from the authorities concerned. The Contractor shall not lay his temporary moorings such as to interfere with the port traffic and such moorings shall be removed if and when required by the Employer.

**54 Cost of Repairs**

Loss or damage to the Works or Materials to be incorporated in the Works between the Start Date and the end of the Defects Liability period shall be remedied by the Contractor at the Contractor's cost if the loss or damage arises from the Contractor's acts or omissions.

**E. Finishing The Contract**  
**55 Completion**

After completion of the work, the Contractor will serve a written notice to the Engineer or his nominee/Employer to this effect. The Engineer or his nominee/Employer upon receipt of this notice shall conduct a complete joint survey of the work within 7 days and prepare a defects list jointly. The defects pointed out by the Engineer or his nominee/ Employer would be rectified by the Contractor within 14 days and thereafter acceptance report be signed jointly by the Contractor and the Employer. This joint acceptance report shall be treated as \_Completion Certificate'.

**Substantial Completion of Parts**

If any part of the Permanent Works has been substantially completed and satisfactorily passed any Tests on Completion prescribed by the Contract, the Engineer may issue a Taking-Over Certificate in respect of that part of the Permanent works before completion of the whole of the Works and, upon the issue of such Certificate, the Contractor shall be deemed to have undertaken to complete with due expedition any outstanding work in that part of the Permanent Works during the Defects Liability Period.

**Surfaces Requiring Reinstatement**

Provided that a Taking Over Certificate given in respect of any Section or part of the Permanent Works before completion of the whole of the Works shall not be deemed to certify completion of any ground or surfaces requiring reinstatement, unless such Taking Over Certificate shall expressly so state.

**56 Taking Over**

The Engineer or his nominee shall take over the Site and the Works within seven days of the Engineer or his nominee issuing a certificate of Completion.

**Taking Over Certificate**

When the whole of the Works have been substantially completed and have satisfactorily passed any Tests on Completion prescribed by the Contract, the Contractor may give a notice to that effect to the Engineer, with a copy to the Employer, accompanied by a written undertaking to finish with due expedition any outstanding work during the Defects Liability Period. Such notice and undertaking shall be deemed to be a request by the Contractor for the Engineer or his nominee to issue a Taking- over Certificate in respect of the Works. The Engineer or his nominee shall, within 21 days of the date of delivery of such notice, either issue to the Contractor, with a copy to the Employer, a Taking- Over Certificate, stating the date on which, in his opinion, the Works were substantially completed in accordance with the Contract, or give instruction in writing to the Contractor specifying all the work which in the Engineer's opinion, is required to be done by the Contractor before the issue of such Certificate. The Engineer or his nominee shall also notify the Contractor of any defects in the Works affecting substantial completion that may appear after such instructions and before completion of the Works specified therein. The Contractor shall be entitled to receive such Taking Over Certificate within 21 days of completion, to the satisfaction of the Engineer or his nominee, of the Works so specified and remedying any defects so notified.

**Taking Over of Sections or Parts**

Similarly, in accordance with the procedure set out in above Clause 55, the Contractor may request and the Engineer or his nominee shall issue a Taking Over Certificate in respect of :

- (a) Any Section in respect of which a separate Time for Completion is provided in the Contract Data , or
- (b) Any substantial part of the Permanent Works which has been both completed to the satisfaction of the Engineer and, otherwise than as provided for in the Contract, occupied or used by the Employer, or
- (c) Any part of the Permanent Works which the Employer has elected to occupy or use prior to completion (where such prior occupation or use is not provided for in the Contract or has not been agreed by the Contractor as a temporary measure).

**57 Final Account**

The Contractor shall supply to the Engineer or his nominee a detailed account of the total amount that the Contractor considers payable under the Contract within 30 days of issue of Taking Over Certificate and the Engineer or his nominee shall certify any final payment that is due to the Contractor within 60 days of receiving the Contractor's

account if it is correct and complete. If it is not, the Engineer or his nominee shall issue within 30 days a schedule that states the scope of the corrections or additions that are necessary for the correction. If the Final Account is still unsatisfactory after it has been resubmitted the Engineer or his nominee shall decide on the amount payable to the Contractor and issue a payment certificate, within 60 days of receiving the Contractor's revised account.

**58 Submission of „As-built Drawings“**

As built Drawings are required to be submitted by the Contractor by the dates stated in the Contract Data. If the Contractor does not supply the Drawings and/or manuals by the dates stated in the Contract Data, or they do not receive the Engineer or his nominee's approval, the Engineer or his nominee shall withhold the amount stated in the Contract Data from payments due to the Contractor.

**59 Termination**

The Employer or the Contractor may terminate the Contract if the other party causes a fundamental breach of the Contract.

Fundamental breaches of Contract include, but shall not be limited to the following:

- (a) The Contractor stops work for 28 days when no stoppage of work is shown on the current Program and the stoppage has not been authorised by the Engineer or his nominee:
- (b) The Engineer or his nominee instructs the Contractor to delay the progress of the Works and the instruction is not withdrawn within 28 days.
- (c) The Employer or the Contractor becomes bankrupt or goes into liquidation other than for a reconstruction restructure or amalgamation.
- (d) A payment certified by the Engineer or his nominee is not paid by the Employer to the Contractor within 50 days of the date of the Engineer or his nominee's certificate:
- (e) The Engineer or his nominee gives Notice that failure to correct a particular Defect is a fundamental breach of Contract and the Contractor fails to correct it within a reasonable period of time determined by the Engineer or his nominee.
- (f) The Contractor does not maintain a security which is required.
- (g) The Contractor has delayed the completion of works by the number of days for which the maximum amount of liquidated damages can be paid as defined in the Contract data and
- (h) If the Contractor, in the judgment of the Employer has engaged in corrupt or fraudulent practices in competing for or in the executing the Contract.
- (i) The Contractor threatens or misbehaves with or physical attack on any of the employee / officer of the Port

For the purpose of this paragraph: — corrupt practice means the offering, giving, receiving or soliciting of anything of value to influence the action of a public official in the procurement process or in contract execution.—Fraudulent practice means a misrepresentation of facts in order to influence a procurement process or the execution of a contract to the detriment of the Employer, and includes collusive practice. Bidders (prior to or after bid submission) designed to establish bid prices at artificial non-competitive levels and to deprive the Employer of the benefits of free and open competition.

When either party to the Contract gives notice of a breach of contract to the Employer for a cause other than those listed under Sub Clause 59.2 above, the Employer shall decide whether the breach is fundamental or not.

Notwithstanding the above, the Employer may terminate the Contract for convenience subject to payment of compensation to the Contractor including loss of profit on

uncompleted works. Loss of profit shall be calculated on the same basis as adopted for calculation of extra/additional items.

If the Contract is terminated the Contractor shall stop work immediately, make the Site safe and secure and leave the Site as soon as reasonably possible.

**60 Payment upon Termination**

If the Contract is terminated because of a fundamental breach of Contract by the Contractor, the Engineer or his nominee shall issue a certificate for the value of the work done less advance payments received upto the date of the issue of the certificate, less other recoveries due in terms of the contract, less taxes due to be deducted at source as per applicable law and less any extra cost of completing the Works through other means which may be incurred by the Employer. If the total amount due to the Employer exceeds any payment due to the Contractor, the difference shall be a debt payable to the Employer.

If the Contract is terminated at the Employer's convenience or because of a fundamental breach of Contract by the Employer, the Engineer or his nominee shall issue a certificate for the value of the work done, the reasonable cost of removal of Equipment repatriation of the Contractor's personnel employed solely on the Works, and the Contractor's costs of protecting and securing the Works and loss of profit on uncompleted works less advance payments received up to the date of the certificate, less other recoveries due in terms of the contract and less taxes due to be deducted at source as per applicable law.

**61 Property**

All materials on the Site, Plant, Equipment, Temporary Works and Works for which payment has been made to the Contractor by the Employer, are deemed to be the property of the Employer, if the Contract is terminated because of a Contractor's default.

**62 Release from Performance**

If the Contract is frustrated by the outbreak of war or by other event entirely outside the control of either the Employer or the Contractor, the Engineer or his nominee shall certify that the Contract has been frustrated. The Contractor shall leave the Site and stop work as quickly as possible after receiving this certificate and shall be paid for all work carried out before receiving it and for any work carried out afterwards to which commitment was made.

**F. Labour Laws And Miscellaneous Clauses**

**63 Labour**

The Contractor shall, unless otherwise provided in the Contract, make his own arrangements for the engagement of all staff and labour, local or other, and for their payment, housing, feeding and transport.

The Contractor shall, if required by the Engineer or his nominee, deliver to the Engineer or his nominee a return in detail, in such form and at such intervals as the Engineer or his nominee may prescribe, showing the staff and the numbers of the several classes of labour from time to time employed by the Contractor on the Site and such other information as the Engineer or his nominee may require.

**64 Compliance with labour regulations.**

During continuance of the contract, the Contractor and his sub Contractors shall abide at all times by all existing labour enactment and rules made there under, regulations, notifications and bye laws of the State or Central Government or local authority and any other labour law (including rules) regulations, bye laws that may be passed or notification that may be issued under any labour law in future either by the State or Central Government or the local authority. Salient features of some of the major labour

laws that are applicable to construction industry are given below. The Contractor shall keep the Employer indemnified in case any action is taken against the Employer by the competent authority on account of contravention of any of the provisions of any Act or rules made there under, regulations or notifications including amendments. If the Employer is caused to pay or reimburse such amounts as may be necessary to cause or observe, or for non-observance of the provisions stipulated in the notifications/ bye laws/ Acts/ Rules/ regulations including amendments, if any, on the part of the

Contractor the Engineer or his nominee/Employer shall have the right to deduct any money due to the Contractor including his amount of performance security. The Employer/Engineer or his nominee shall also have right to recover from the Contractor any sum required or estimated to be required for making good the loss or damage suffered by the Employer.

The employees of the Contractor and the Sub-Contractor in no case shall be treated as the employees of the Employer at any point of time.

**65 Safety, Security and Protection of the Environment.**

Subject and without prejudice to any other provision of the Contract, the Contractor shall take all reasonable precautions:

- a) In connection with the sea or any harbours, docks, rivers, streams waterways drains, watercourses, lakes, reservoirs and the like to prevent:
  - (i) Silting
  - (ii) Erosion of their beds or balks
  - (iii) Pollution of the water so as to affect adversely the quality or appearance thereof or cause injury or death to animal and plant life.
- b) In connection with underground water resources (including percolating water) to prevent
  - (i) Any interference with the supply to or abstraction from such sources
  - (ii) Pollution of the water so as to affect adversely the quality thereof.
- (c) All works shall be carried out without unreasonable noise and disturbance. The Contractor shall indemnify the Employer from and against any liability for damages on account of noise or other disturbance created while or in carrying out the work and from and against all claims, demands, proceedings, damages, costs, charges and expenses whatsoever in regard or in relation to such liability.
- (d) The Contractor at his own cost shall make such provisions for lighting of Works, Temporary Works, Materials and Plant and shall provide all such marks and lights as may be required by the Employer or the Engineer or any other authority having jurisdiction over the Site together with all labour stores and services required for their efficient working and use at any time, day or night.
- (e) The Contractor shall also provide at his own cost every description of watching and maintenance required in connection with the foregoing, and all other services for protecting and securing all places dangerous whether to Contractor's workmen or to other persons until the Works are handed over to the Employer, or till such time when the Engineer decides that such services are no longer required.
- (f) All lights provided by the Contractor shall be placed or screened such as not to interfere with any navigation lights or with any traffic or signal lights of any local or other authority.

**66 Insurance of Works and Contractor's Equipment**

The Insurance shall be issued by any Insurance Company from its Branch at Cochin which has been determined by the Contractor to be acceptable to the Employer.

**67 War Risks Insurance**

If the Contractor receives instructions from the Employer to insure against war risks, such insurance if normally available shall be effected, at the cost of the Employer, with the Insurance Company acceptable to the Employer and shall be in the joint names of the Employer and the Contractor.

**68 Royalties**

Except where otherwise stated, the Contractor shall pay all tonnage and other royalties, rent and other payments or compensation. If any, for getting stone, sand, gravel, clay or other materials by him and his subordinates and his sub contractors and required for the works, at the rates and such conditions as notified by the State Government and shall be realized from the Contractor by way of deductions from the interim certificates and/or final certificate for payments to the Contractor for the gross quantity of material used for or in connection with the work. The royalty will not be deducted if the Contractor submits the Mineral Dispatch Permit (MDP) for the quantity executed by the Contractor for the requisite quantity of material incorporated in works for which MDPB issued.

**69 Transport of Contractor's Equipment or Temporary Works**

If it is found necessary for the Contractor to move one or more loads of heavy constructional plant or equipment materials or pre-constructed units or parts of units of work over roads, highways or bridges on which such oversized and overweight items are not normally allowed to be moved, the Contractor shall obtain prior permission from the concerned authorities. Payments for complying with the requirements, if any, for protection of or strengthening of the roads, highways or bridges shall be deemed to be included in his contract price.

**70 Transport of Materials or Plant**

The Contractor shall save harmless and indemnify the Employer in respect of all claims, proceedings, damages, costs, charges and expenses whatsoever arising out of or in relation to any claim made by the concerned authorities in respect of damage or injury to roads, highways or bridges. In case of failure of the Contractor to settle such claims and in case the Employer is held responsible for payment to the authorities, then the Employer shall settle the claim and the Employer's expenses in this regard, as certified by the Engineer, may be deducted by the Employer from any money due or to become due to the Contractor and the Engineer shall notify the Contractor accordingly with a copy to the Employer.

**71 Labour Laws & Regulations**

The Contractor shall at all times during the continuance of the Contract comply fully with all existing Acts, regulations and bye-laws including all statutory amendments and re-enactment of State or Central Govt. and other local authorities and any other enactments and act that may be passed in future either by the State or the Central Govt. or local authority, including Indian Workmen's Compensation Act, Contract Labour (Regulation And Abolition) Act 1970 and Equal Remuneration Act 1976, Employees' State Insurance Act, 1948, Factories Act, Minimum Wages Act, Provident Fund Regulations. Employees' Provident Fund Act and schemes made under the same Act, Health and Sanitary Arrangements for Workmen, Insurance and other benefits and shall keep the Employer indemnified in case any action is commenced for contravention by the Contractor. If the Employer is caused to pay or reimburse any amounts as may be necessary to cause or observe, or for non-observance of the provisions stipulated here-forth on the part of the Contractor, the Engineer shall have the right to recover from the Contractor any sum required estimated to be required for making good the loss or damage suffered by the Employer. The Contractor shall maintain the records prescribed under ESI Regulations & EPF scheme and make the contribution towards ESI and EPF

in respect of persons employed by Contractor. The Contractor shall also make available such records for inspection by ESI Inspector and EPF organization during the inspection and furnish copies of all such records to the Employer regularly.

71.1. **Accident Prevention Officer**

The Contractor shall have on his staff on site an officer dealing with all matters regarding safety and protection against, accidents of all staff and labour. This officer shall be qualified for this work and shall have the authority to issue instructions and shall take protective measures to prevent accidents.

**Disorderly Conduct**

The Contractor shall at all times take all reasonable precautions to prevent any unlawful, riotous or disorderly conduct by or amongst his staff and labour and for the preservation of peace and protection of Persons and property in the neighborhood of the Works from the same.

**Health and Safety**

Due precautions shall be taken by the Contractor, and at his own cost, to ensure the safety of his staff and labour and, in collaboration with and to the requirements of the local health authorities, to ensure that medical staff, first aid equipment and stores, sick bay and suitable ambulance services are available at the camps, housing and on the site at all times throughout the period of the Contract and that suitable arrangements are made for the prevention of epidemics and for all necessary welfare and hygiene requirements.

**Supply of Water**

The Contractor shall, so far as is reasonably practicable, having regard to local conditions provide on the Site, to the satisfaction of the Engineer's Representative, an adequate supply of drinking and other water for the use of the Contractor's staff and work people.

**Alcoholic Liquor or Drugs**

The Contractor shall not import, sell, give, barter or otherwise dispose of any alcoholic liquor, or drugs or permit or suffer any such importation, sale, gift, barter disposal by his sub-contract agents or employees.

**Arms and Ammunition**

The Contractor shall not give, barter or otherwise dispose of to any persons or person, any arms or ammunition of any kind or permit or suffer the same as aforesaid.

**Festivals and Religious Customs**

The Contractor shall in all dealings with labour in his employment have due regard to all recognised festivals, days of rest and religious or other customs.

**Epidemics**

In the event of any outbreak of illness of an epidemic nature, the Contractor shall comply with and carry out such regulations, orders and requirements as may be made by the Government, or the local medical or sanitary authorities for the purpose of dealing with and overcoming the same.

**Employment of Person in the Service of Others**

The Contractor shall not recruit or attempt to recruit his staff and labour from amongst persons in the service of the Employer or other agencies engaged for any works of the Employer.

**Housing for Labour**

Save in so far as the Contract otherwise provides, the Contractor shall provide and maintain such accommodation and amenities as he may consider necessary for all his staff and labour employed for the purposes of or in connection with the Contract, including all fencing water supply (both for drinking and other purposes), electricity

supply, sanitation, cook houses fire prevention and fire-fighting equipment, furniture other requirements in connection with such accommodation or amenities. On completion of the Contract, unless otherwise agreed with the Employer, the temporary camps/housing provided by the Contractor, shall be removed and the site reinstated to its original condition, all to the approval of the Engineer. The land for construction of labour camps shall be allotted only outside the security area to the extent available and such areas allotted as per the prevailing lease rent.

#### **Fair Wages, Records, Inspection**

The Contractor shall pay the labourers engaged by him on the work not less than a fair wage which expression shall mean whether for time or piecework the respective rates of wages as notified under the provisions of the Minimum Wages Act from time to time.

The Contractor shall maintain records of Wages and other remuneration paid to his employee in such form as may be convenient and to the requirements of the Employer/Engineer and the Labour Enforcement Officer (Central), Ministry of Labour, Govt. of India, or such other authorized person appointed by the Central Govt. The Contractor shall allow inspection of the aforesaid Wage Records and Wage Slips to the Engineer and to any of his workers or to his agent at a convenient time and place after due notice is received, or to any other person authorized by him on his behalf.

#### **Reporting of Accidents**

The Contractor shall report to the Engineer details of any accident as soon as possible after its occurrence. In the case of any fatality or serious accident, the Contractor shall, in addition, notify the local police authorities immediately by the available means.

#### **Observance by Sub-Contractors**

The Contractor shall be responsible for observance by his sub-Contractors of the foregoing provisions.

#### **Port Entry Permission**

The Contractor shall submit prior application for Port entry passes to the concerned Port authority for his labours and the staffs engaged in the works.

The Contractor shall retain the original passes obtained by them in respect of their labour and staff engaged in the Works and produce the same to the Engineer as and when called for. It should not be either destroyed or allowed to be taken by the labour/staff after its use.

#### **Site - Protected Area**

The Site of Work is a protected area. Entry to the Port premises is regulated by entry passes. These passes will be issued by the Central Industrial Security Force or any other authority authorized by the Employer. The Contractor should furnish a list of person for whom the passes are to be issued to the Engineer and arrange to obtain the passes from the appropriate authority, based on the recommendation of the Engineer and abide by the Rules of the Cochin Port Authority with regard to entry etc. For the entry of trucks and other vehicles also, the Contractor should obtain necessary permits at his own cost . The Contractor shall retain the original passes obtained by them in respect of their labour and staffs engaged in the Works and produce the same to the Engineer as and when called for. It should not be either destroyed or allowed to be taken by the labour/staff after its use.

## **72 Life Saving Appliances And First Aid**

The Contractor shall provide and maintain upon the Works sufficient proper and efficient life saving appliances and first aid equipment to the approval of the Engineer. The appliances and equipment shall be available for use at all times.

**73 Action in case Work not done as per Specifications**

All works under or in course of execution or executed in pursuance of the contract shall at all times be open and accessible to the inspection and supervision of the Engineer or his authorised subordinates in charge of the work and all the superior officers, officer of the Quality Control Organisation of the Department, Vigilance Commissions, and the Contractor shall, at all times, during the usual working hours and at all other times at which reasonable notice of the visit of such officers has been given to the Contractor, either himself be present to receive orders and instructions or have a responsible agent duly accredited in writing, present for that purpose. Orders given to the Contractor's agent shall be considered to have the same force as if they had been given to the Contractor himself.

If it shall appear to the Engineer or his nominee or his authorised subordinates in charge of the work or to the Chief Vigilance Commissioner or his subordinate officers, that any work has been executed with unsound, imperfect, or unskillful workmanship, or with materials or articles provided by him for the execution of the work which are unsound or of a quality inferior to that contracted or otherwise not in accordance with the contract the Contractor shall, on demand in writing which shall be made within twelve months of the completion of the work from the Engineer or his nominee specifying the work, materials or articles complained of notwithstanding that the same may have been passed, certified and paid for forthwith rectify, or remove and reconstruct the work so specified in whole or in part, as the case may require or as the case may be, remove the materials or articles so specified and provide other proper and suitable materials or articles at his own charge and cost. In the event of the failing to do so within a period specified by the Engineer or his nominee in his demand aforesaid, then the Contractor shall be liable to pay compensation at the same rate as under Clause 49 of the contract (for non-completion of the work in time) for this default.

In such case the Engineer or his nominee may not accept the item of work at the rates applicable under the contract but may accept such items at reduced rates as the competent authority may consider reasonable during the preparation of on account bills or final bill if the item is so acceptable without detriment to the safety and utility of the item and the structure or he may reject the work outright without any payment and/or get it and other connected and incidental items rectified, or removed and re-executed at the risk and cost of the Contractor. Decision of the Engineer or his nominee to be conveyed in writing in respect of the same will be final and binding on the Contractor.

**74 Action where no Specifications are specified**

In the case of any class of work for which there are no such specifications as referred to in Clause 16, such work shall be carried out in accordance with the Bureau of Indian Standards Specifications. In case there is no such specification in Bureau of Indian Standards, the work shall be carried out as per manufacturer's specifications. In case there are no such specifications as required above, the work shall be carried out in all respects in accordance with the instructions and requirements of the Engineer or his nominee.

**75 Bribes**

If the Contractor, or any of his Sub Contractors, agents or servants gives or offers to give to any person any bribe, gift, gratification or commission as an inducement or reward for doing or forbearing to do any action in relation to the Contract or any other contract with the Employer, or for showing or forbearing to show favour or disfavor to any person in relation to the Contract or to any other contract with

the Employer, then the Employer may enter upon the Site and the works and terminate the employment of the Contractor and the provisions of Clause 59 hereof shall apply as if such entry and termination had been made pursuant to that Clause.

- (i) The bidders shall give an undertaking that they have not made any payment or illegal gratification to any person/authority connected with the bid process so as to influence the bid process and have not committed any offence under the Prevention of Corruption Act in connection with the bid.
- (ii) The bidders shall disclose any payments made or proposed to be made to any intermediaries (agents etc) in connection with the bid.

**76 Details to be Confidential**

The Contractor shall treat the details of the contract as private and confidential, save insofar as may be necessary for the purposes thereof, and shall not publish or disclose the same or any particulars thereof in any trade or technical paper or elsewhere without the previous consent in writing of the Employer. If any dispute arises as to the necessity of any publication or disclosure for the purpose of the Contract the same shall be referred to the decision of the Employer whose award shall be final.

**77 Contractor's Temporary works, office etc**

The Contractor shall submit to the Engineer for his approval not less than 15 days before commencement of erection of any part of Temporary Works, drawings and detailed proposals for the method of construction of Temporary works such as office, store, false work and temporary platforms, pre-casting yard, workshop, etc. which he intends to construct for the execution of the contract and no such work shall be constructed before obtaining the written approval of Engineer or his nominee. These temporary works, office, store etc. shall be erected at or near the work area subject to approval of the Employer and the land space for the same will be allotted free of ground rent to the extent available. The Contractor shall obtain permission for any Temporary Works and would ensure that during execution of works the statutory requirements of the concerned authorities such as Cochin Port Authority, Police, Customs, etc. would be complied with.

**Submission of Reports, Returns etc**

All reports, statements, returns, drawings, diagrams etc. which the Contractor is required to submit to the Engineer during the progress of the Works, shall be furnished in triplicate without any additional cost.

**78 Water Supply**

Water required for the construction works including curing work shall be arranged by the Contractor on his own at his cost.

**79 Power Supply**

The Electricity connection for lighting, welding and other mechanical works to the extent available will be made available by the Employer within the Port area. Drawing of power lines/cables etc from the available source of supply of power to the actual work site, providing switches and making connections etc. shall be arranged by the Contractor at his cost. The temporary lines and connections by the Contractor shall be approved by the Engineer's representative before availing power. The Contractor shall provide Energy Meter to read consumption in units.

The Contractor shall indicate his requirement of power to the Engineer within 15 days from the date of the letter of acceptance of the tender. The Contractor shall pay to the

Employer, the power charges as per the prevailing Tariff schedule of Cochin Port Authority in force during the work of the Contractor. The Contractor shall also pay the connection and disconnection charges as applicable.

The Contractor shall submit a complete drawing of the power points, wiring, diagram indicating all electrical loads, earthing etc. in complete shape along with the completion report. The Energy Meter provided is calibrated by Kerala State Electrical Inspectorate

/TMR division, KSEB and such a Certificate to be produced. For non supply of power at any stage port will not be responsible and the Contractor shall not have any claim whatever for loss or damage.

If there is any disruption in the power supply due to supply failure/restrictions imposed by the Kerala State Electricity Board, the department shall not be held responsible and the Contractor has to make suitable alternative arrangements like generator, welding set etc. at their cost.

#### **80 Taxes and Duties**

The Contractor shall pay Sales Tax, Excise Duty and other levies as applicable from time to time in respect of all materials, equipment and other items purchased for the work.

#### **Sales / Turnover Tax on Works Contract**

Deduction of Sales/Turnover tax on works Contract shall be made by the Employer from each certificate of payment to the Contractor at the rate applicable for such Contractors, as TDS or such other rates as may be specified by the State Government from time to time. TDS certificates will be issued to the Contractor which he may produce before the Tax Authority for adjustment against his tax liability as per assessment.

#### **Income Tax**

The Contractor and his staff shall be responsible for payment of all personal income taxes to the concerned authorities as per the law in force from time to time. Deduction of Income Tax shall be made by the Employer from each certificate of payment to the Contractor at the rate of 2% plus surcharge or such other rates as may be specified by the Central Government from time to time, on the gross amount of the Contractor's bill for payment.

#### **81 Noise and Disturbance**

All works shall be carried out without unreasonable noise and disturbance. The Contractor shall indemnify the Employer from and against any liability for damages on account of noise or other disturbance created while or in carrying out the work and from and against all claims demands proceedings damages costs charges and expenses whatsoever in regard or in relation to such liability.

#### **82 Safety Code**

Necessary Indian Dock Safety regulations for the safety purpose shall be adhered to by the Contractor and he will be held responsible for any violations of the same. The set of such conditions (regulation) is available with Cochin Port Authority and the Contractor is required to go through it before tendering. Besides the above, the Contractor shall also scrupulously adhere to and observe the following safety codes:

- (i) The Contractor has to provide sufficient barricades to site of work so that traffic plying nearby should not damage the recently concreted work. In case of any damage on account of above, the entire responsibility will remain with Contractor and nothing extra will be paid on this account.
- (ii) Suitable and strong scaffolds should be provided for the workmen for all work that cannot be safely done from ground.
- (iii) No portable single ladder shall be over 8 meters in length. The width between the side rails shall not be less than 30 cm (clear) and the distance between the two adjacent rungs shall not be more than 30 cm.
- (iv) Hoisting machines and tackles used in the works including their attachments, anchorage and supports shall be in perfect condition as per stipulations of the relevant Rules. The ropes used an hoisting or lowering materials or as means or suspension shall be of durable quality and adequate strength and free from defects.
- (v) The excavated material shall no be placed within 1.5 meters of the edge of the trench or half of the depth of the trench, whichever is more. All trenches and excavation shall be provided with necessary fencing to lighting. Every opening in the floor of a building or in a working platform be provided with suitable fence to prevent the fall of persons or materials. No floor, roof or other parts of the structure shall be so overloaded with debris or materials as to render it unsafe.
- (vi) Workers employed on mixing and handling materials such cement, cement mortars concrete, lime mortar and asphalt shall be provided with protective footwear and rubber hand gloves and thin cloth for covering face and head.
- (vii) Those engaged in welding work shall be provided with welder protective eye shield and glove.
- (viii) All safety rules shall be strictly followed while working on live electrical systems or installations as stipulated in the relevant Rules.

### 83 **Port Authority Rules**

The Contractor shall observe the Conservancy Rules relating to the harbour and shall always take such necessary additional steps to keep the harbour waters free of noxious or unhygienic matters coming from his works as are required by the Employer. Under no circumstances shall inflammable materials be allowed to spill into the harbour waters.

The Contractor shall always observe and comply with the working rules and regulations of the Port Authority in force or as issued from time to time.

The Contractor's plants, equipments, floating crafts, dredgers, materials etc. which are brought to site for facilitating the proper execution of the contract work within the port area are not liable to port dues and charges like wharfage, berth hire and other charges during the period of contract and until expiry of defect liability period.

### 84 **Execution of work**

The Contractor shall be required to execute the work in such a way so as not to cause any damage, hindrance or interference with port activities going on in the area or nearby. He should not also deposit the materials at such places which may cause inconvenience to the public and the work going on in the nearby area. The Contractor shall have to make good all damages done by him to the structures nearby while executing the work and no extra payment shall be made to him on that account.

All the materials required to be used in the work shall have to be got approved from the Engineer-in-Charge before stacking at the site of work.

Barricading, including proper lighting arrangement in the night at the required places shall have to be provided by the Contractor at his own cost, including necessary arrangements for proper movement of traffic by carefully maintained approaches and road diversions with suitable sign boards for indications of road signs etc. as directed by the Engineer-in-Charge.

**85 Drawings & Designs**

- (a) General details of the works are shown on the drawings accompanying the tender document. The Engineer will supply to the Contractor from time to time during the progress of the works such further working drawings as will be necessary in his opinion for the proper and adequate execution and maintenance of the Works in accordance with the Engineer's designs and/or any modification thereof as decided by the Engineer and the Contractor shall carry out the work in accordance with the said working drawings. Two sets of such working drawings will be issued. If the Contractor requires more sets he will have to make his own arrangement at his cost. Residual Design, Detailing & Engineering: - Generally, detailed design and engineering of the work shall be provided by the Engineer. During execution of the work the residual design, detailing and engineering, if needed, is to be carried out by the Contractor at no extra cost to the Employer. Such design, detailing & engineering shall be got approved by the Contractor from the Engineer. For equipments/ Installations detailed drawings need to be produced by the Contractor at no extra cost to the Employer. Such detailing & engineering shall be got approved by the Contractor from the Engineer.
- (b) In the event of the Contractor proposing any alteration/ modification to the Engineer's design, detail, method of construction, he shall at his own expenses prepare and submit for approval of the Engineer copies in duplicate (in the first instance) of detailed working drawings which may be required for such alteration/ modification and at the same time call the attention of the Engineer to any alternative detail or modification of the contract drawings which the Contractor may wish to make at least 30 days prior to the commencement of the work or part of the work to which such drawings relate. The Contractor shall at the same time, if so required by the Engineer, furnish calculation sheets in duplicate relating to the strength and anticipated deflections in respect of such altered/ modified works. The Engineer will, after any such alteration which he may approve, record on the copies as amended his approval and will return one copy of the drawings and calculation sheets to the Contractor, who shall carry out the work in accordance therewith. The Contractor shall forward to the Engineer three additional copies of the working drawings and calculation sheets as approved in addition to these working drawings and calculation sheets as approved. In addition to these, working drawings are also to be submitted (the same procedure as in the case of the Contractor) in respect of any work proposed to be executed by sub-Contractors. The approval of the Engineer of all or any of the calculation sheets, drawings shall not relieve the Contractor of responsibility in connection with the execution of the altered/ modified or Sub Contractor's work.
- (c) Three complete sets of tracing film of all drawings showing every and all works 'As Made' under the Contract shall be made by the Contractor at his own expense and

delivered to the Engineer within one month of the completion of the various sections of the work or at such times as directed by the Engineer. All departure /alteration /modifications from the Contract Drawings and supplementary working drawings issued by the Engineer also shall be incorporated in the "As Built" drawings. The drawings shall be fully dimensioned, of an approved size and as approved by the Engineer.

**86**     **Monsoon Period**

Normally Monsoon period will be reckoned from 1<sup>st</sup> June to 30<sup>th</sup> September.

**87**     **Reports**

The following reports shall be submitted for review as an input to the Management meeting to be held as per Clause No 31 of Conditions of Contract

**Daily reports**

The Contractor shall submit daily report indicating daily activities, weather condition, actual manpower, equipment and the materials arriving on site.

**Monthly Reports**

Monthly progress reports shall be prepared by the Contractor and submitted to the Engineer in triplicate. The first report shall cover the period up to the end of the first calendar month following the Commencement Date. Reports shall be submitted monthly thereafter, each within 7days after the last day of the period to which it relates. Reporting shall continue until the Contractor has completed all work, which is known to be outstanding at the completion date, stated in the Taking-Over Certificate for the Works.

Each report shall include:

- a) Charts and detailed descriptions of progress, including each stage of design (if any), Contractor's Documents, procurement, manufacture, delivery to Site, construction, erection and testing; and including these stages for work by each Sub-Contractor,
- b) Photographs in hardcopy & digital copy and videography in two sets showing the various stages of progress on the Site monthly;
- c) For the supply of manufactured items, the name of the manufacturer, manufacture location, percentage progress, and the actual or expected dates of:
  - (i) Commencement of manufacture,
  - (ii) Contractor's/ Engineer's inspections,
  - (iii) Tests,
  - (iv) Shipment and arrival at the Site;
- d) Copies of quality assurance documents, test results and certificates of Materials;
- e) Safety statistics, including details of any hazardous incidents and activities relating to environmental aspects and public relations; and
- f) Comparisons of actual and planned progress, with details of any events or circumstances which may jeopardise the completion In accordance with the Contract, and the measures being (or to be) adopted to overcome delays.

**88**     **Completion Documents**

To treat that the work has been completed and issue a final payment certificate, the following documents will be deemed to form the completion

documents:

- i) The Technical documents according to which the work was carried out.
- ii) The set of construction drawings showing therein the modifications and corrections made during the course of execution signed by the Engineer.
- iii) Certificates of final levels and dimensions as set out for various works.
- iv) Certificates of tests performed for various works.
- v) As Built Drawings.

**89 Changes in firm's Constitution to be intimated**

The Contractor shall intimate the Engineer in writing of any change made in the constitution of the firm

**90 Indemnities**

The Contractor shall indemnify and hold harmless the Employer, the Employer's Personnel, and their respective agents, against and from all claims, damages, losses and expenses (including legal fees and expenses) in respect of:

- (a) Bodily injury, sickness, disease or death, of any person whatsoever arising out of or in the course of or by reason of the Contractor's design (if any), the execution and completion of the Works and the remedying of any defects, unless attributable to any negligence, willful act or breach of the Contract by the Employer, the Employer's Personnel, or any of their respective agents, and
- (b) Damage to or loss of any property, real or personal (other than the Works), to the extent that such damage or loss:
  - (i) Arises out of or in the course of or by reason of the Contractor's design (if any), the execution and completion of the Works and the remedying of any defects, and
  - (ii) Is attributable to any negligence, willful act or breach of the Contract by the Contractor, the Contractor's Personnel, their respective agents, or anyone directly or indirectly employed by any of them.

**G. Salient Features Of Some Major Laws Applicable To Establishments Engaged In Construction Work.**

- (a) Workmen Compensation Act 1923:- The Act provides for compensation in case of injury by accident arising out of and during the course of employment.
- (b) Payment of Gratuity Act 1972: Gratuity is payable to an employee under the Act on satisfaction of certain conditions on separation if an employee has completed 5 years service or more on death at the rate of 15 days wages for every completed year of service. The Act is applicable to all establishments employing 10 or more employees.
- (c) Employees P.F and Miscellaneous Provision Act 1952: The Act Provides for monthly contributions by the Employer plus workers @ 12% / 8.33%. The benefits payable under the Act are:
  - (i) Pension or family pension on retirement or death, as the case may be.
  - (ii) Deposit linked insurance on the death in harness of the worker.
  - (iii) Payment of P.F accumulation on retirement/death etc.

The employees employed by the Contractor for the work of Port Authority have to be enrolled under the relevant scheme of the EPF & MP Act 1952. The Contractor shall produce documents pertaining to the same for verification to the Engineer/ his nominee. Further the Contractor has to pay the necessary monthly contributions to the said scheme in respect of the employees employed by him for the work of CoPT and shall produce necessary document to show that the monthly contribution in respect of these employees due to the said scheme are paid.

In case the contractor has not paid the EPF contribution same will be recovered in the running bill and paid to the EPF Organization. Any delay in payment of contribution payable under the Act may be recovered as an arrear of Land Revenue

- (d) Maternity Benefit Act 1951:-The Act provides for leave and some other benefits to workmen/ employees in case of confinement or miscarriage etc.
- (e) Contract Labour (Regulation & Abolition) Act 1970:-The Act provides for certain welfare measures to be provided by the Contractor to contract labour and in case the Contractor fails to provide, the same are required to be provided, by the Principal Employer by Law. The Principal Employer is required to- take Certificate of Registration and the Contractor is required to take license from the designated Officer. The Act is applicable to the establishments or Contractor of Principal Employer if they employ 20 or more contract labor.
- (f) Minimum Wages Act 1948: The Employer is supposed to pay not less than the Minimum Wages fixed by appropriate Government as per provisions of the Act if the employment is a scheduled employment Construction of Buildings, Roads, Runways are scheduled employment.
- (g) Payment of Wages Act 1936:-It lays down as to by what date the wages are to be paid when it will be paid and what deductions can be made from the wages of the workers.
- (h) Equal Remuneration Act 1979:-The Act provides for payment of equal wages for work of equal nature to Male and Female workers and for not making discrimination against Female employees in the matters of transfers, training and promotions etc.
- (i) Payment of Bonus Act 1965: The Act is applicable to all establishments employing 20 or more employees. The Act provides for payments of annual bonus subject to a minimum of As per the provision of the Act and amendment issued from time to time. The Act does not apply to certain establishments. The newly set-up establishments are exempted for five years in certain circumstances. Some of the State Governments have reduced the employment size from 20 to 10 for the purpose of applicability of this Act.
- (j) Inter-State Migrant workmen's (Regulation of Employment & Conditions of Service) Act 1979:The Act is applicable to an establishment which employs 5 or more inter-state migrant workmen through an intermediary (who has recruited workmen in one state for employment in the establishment situated in another state). The Inter-State migrant workmen, in establishment to which this Act becomes applicable, are required to be provided certain facilities such as housing, medical aid, travelling expenses from home upon the establishment and back,
- (k) The Building and Other Construction workers (Regulation of Employment and Conditions of Service) Act 1996 and the Cess Act of 1996:-All the establishments who carry on any building or other construction work and employs 10 or more workers are covered under this Act. All such establishments are required to pay

cess at the rate not exceeding 2% of the cost of construction as may be modified by the Government. The Employer of the establishment is required to provide safety measures at the Building or Construction work and other welfare measures, such as Canteens, First-Aid facilities. Ambulance, Housing accommodations for workers near the work place etc. The Employer to whom the Act applies has to obtain a registration certificate from the Registering Officer appointed by the Government.

(l) ESI Act, 1948:-

- (i). As per the Govt. Notification dt. 20.7.09, Cochin Port Authority has registered under the ESI Act with ESI Corporation and provision of ESI Act, 1948 are applicable to contract/casual employees drawing wages/Salary upto Rs.15,000/- per month and working in Cochin Port Authority . Workers covered under ESI Act, are entitled for full medical care for self and family. Besides, cash benefit in the event of sickness, maternity and employment injury. Accordingly, the contractual/casual employees drawing wages upto Rs. 15,000/-per month employed either directly by Port Authority or through contractor are covered under ESI Act, 1948. It is obligatory on the part of the employer to calculate and remit ESI contribution comprising of employers' share of 4.75% plus employees' share of 1.75% which is payable on or before 21st of the following month, to which the salary relates.
- (ii). In case the Contractor employs more than 20 employees, they should register their name with ESI scheme as per ESI Act, 1948 and obtain ESI Code. Both Employers share of 4.75% and Employees contribution of 1.75 % (recovered from employees), totally 6.5% to be paid as contribution to ESI in their Code on or before 21st of following month to which the salary relates and acknowledgment for the same shall be submitted to the Port while claiming the bill. The bill without the acknowledgement of ESI contribution will not be entertained. In case the contractor has not paid the ESI contribution same will be recovered in the running bill and paid to the ESI Corporation in contractor's code. Any delay in payment of contribution payable under the Act may be recovered as an arrear of Land Revenue.
- (iii). In case the contractor employs less than 20 employees, the list of employees' name, their father's name, identification proof, one passport photo shall be submitted to the Port Authority. The contribution of ESI amount, both Employers share of 4.75% and Employees of 1.75% (recovered from Employees salary), totally 6.5% shall be paid by the contractor in the Cochin Port Authority Code on or before 21st of the following month to which the salary relates or otherwise payment to the contractor will be withheld. If the contractor fails to comply with the above instruction, then the Principal Employer (Cochin Port Authority) will make payment to the ESI Corporation. Such amount will be deducted from any amount due to the contractor. Any delay in payment of contribution payable under the Act may be recovered as an arrear of Land Revenue.
- (iv). As per the above Government Notification
  - i) All intending tenderer at the time of tender shall disclose all necessary

- documents as to whether they are covered under ESI Act or not.
- ii) in case they are covered under ESI Act, they have to furnish the details of registration.

**COCHIN PORT AUTHORITY**

**SECTION –III**

**SPECIAL CONDITIONS OF CONTRACT**

<b>SL. NO.</b>	<b>CLAUSE/ SECTIONS</b>	<b>DESCRIPTION</b>	<b>PAGE NO.</b>
1	1	General	83
2	2	Rates for Various Items	83
3	3	Liquidated Damages	84
4	4	Care of Works	84
5	5	Procurement of materials	84
6	6	Completion Period	84
7	7	Officer in-charge	84
8	8	Tests and Inspection	85
9	9	Scraps	85
10	10	Modifications to General Conditions of Contract (GCC	85

**1. General:**

- 1.1 Special Conditions shall be read in conjunction with the General Conditions of Contract, Scope of Work, Specifications, Drawings and any other document forming part of this Contract wherever the context so requires.
- 1.2 Notwithstanding the sub-division of the documents into these separate section and volume every part of each shall be deemed to be supplementary to and complementary of every other part and shall be read with and into the Contract so far as it may be practicable to do so.
- 1.3 Where any portion of the General Conditions of Contract (GCC) is repugnant to or at variance with any provision of the Special Conditions, the provisions of the Special Conditions shall be deemed to over-ride the provisions of the General Conditions of Contract and shall to the extent of such repugnancy of variations, prevail.
- 1.4 The parties shall be governed by the laws of India and exclusive jurisdiction of the courts at Ernakulam.

**2. Rates for Various Items:**

- 2.1 The rates/ lumpsum amount as applicable shall except in so far as the contract otherwise provides, cover all obligations of the Contractor under this contract and all matters and things necessary for the proper completion and maintenance of the

**Cochin Port Authority**  
**TENDER No.MD/PMW/ GHDNS GRAB REPAIRS /2022-24**

Works. The rates / lumpsum amount quoted for each item shall be all inclusive value of the finished Work as per Scope of Work, drawings and specifications and shall cover the cost of all temporary Works, appliances, materials, both for the Works and temporary Works, labour and all other matter in connection with each item quoted for.

- 2.2 The Contractor shall be deemed to have satisfied himself before tendering as to the correctness and sufficiency of his tender for the Works and of the rates and prices stated in the Schedule of Quantities.

**3. Liquidated Damages**

For levying LD as clause 49 of GCC, the Employer is not required to have documentary evidence to quantify or prove the losses suffered by the Employer due to delay in completion of Work by the Contractor, as per Agreement conditions.

**4. Care of Works**

From the commencement to the completion of the Work the Contractor shall take full responsibility for the care of the Work and his employees in connection with the Work thereof and in case any damage, loss or injury shall happen to the Works or any part thereof or to any temporary Work from any cause whatsoever (save and except the excepted risks as defined in clause 12.2 of General Conditions of Contract), the contractor shall at his own cost repair and make good the same so that the Work shall be completed in good order and in conformity in every respect with requirement of the contract. In the event of any such damage, loss or injury happening from any of the excepted risks, the Contractor shall if and to the extent required by the Engineer-in-Charge, make good the same as aforesaid and it will not be to the account of the CoPA Board.

**5. Procurement of materials:-**

- 5.1. The Contractor must make his own arrangements for timely procurement of all materials/spares etc. of specified or approved quality required by him for the efficient and regular execution of the works comprised in this Contract from manufacturers and suppliers concerned. Delay in supply of any of these materials etc. will not be taken as an excuse for not completing the contract within the stipulated period.

**6. Completion Period:-**

- 6.1. Work completion period for each grab will be **2 months (maximum)** from the date of handing over of grab to the contractor. However, the contractor shall make all efforts to complete the work in minimum time. On justifiable circumstance, additional time for completion of the work will be granted by EIC up on request of the contractor.
- 6.2. **The contractor should give a Guarantee of Three months for each repaired grab from the date of fitting the grab in the vessel for operation after repairs, for workmanship /materials used for repairs.**

**7. ENGINEER IN-CHARGE:**

The works shall be carried out as per instruction of the Engineer in-charge or his representatives of the Contract as nominated by the Employer. All Work Completion Certificates will be signed by the MES or his representative. Name of Engineer in-charge will be indicated in the Employer's Letter of Acceptance.

8. TESTS & INSPECTIONS:

1. Right to Inspect: The Deputy Conservator or his representatives shall have the right to inspect the work being carried out under this contract and to test the goods or services to ascertain their conformity to the specifications.
2. Right to Reject: If any inspected or tested goods and/or services fail to conform to the specifications, the Deputy Conservator or his representative may reject them, and the Contractor shall either replace them or make all necessary alterations to meet the requirements of the specifications, without any additional cost to CoPA.
3. Right to Reject at Site: The Deputy Conservator's right to inspect, test, and where necessary, reject the goods and/or services after arrival at the site of installation, shall in no way be limited or waived by reason of the goods or services having been previously inspected, tested and passed by the Deputy Conservator or his representative prior to the dispatch of goods from elsewhere.

9. **Scraps:** All the metal/pipe scraps, any old machineries, damaged spares, other unusable scraps etc, which are not required by CoPA are to be cleared, handled and disposed by the contractor at his own cost, considered which are contractors asset. **While quoting the rates, the cost of such scraps also may considered.**

10. **Modifications to General Conditions of Contract (GCC)**

**The following clauses of GCC shall be replaced and modified as below.**

10.1. **Definitions:** The following Definitions are modified as given below:

The **Completion Date** is the date of completion of the Works as certified by the Engineer or his nominee in accordance with Sub Clause **56.1**

“Yard/Site” means the repair yard (owned or leased) of the bidder in or through which the works are to be executed or carried out and any places used for the purpose of the contract.  
Works/Repairs means repairs and all other related services associated with the repair of Grabs

The "Drawings" shall mean the drawings, issued with the specification.

“Engineer/Engineer-in-charge” : means an Officer of Cochin Port Authority as nominated by the Employer, to be in-charge of the works of this tender.

"Specifications" means the specification referred to in the tender documents if any and any modifications thereof or additions thereto or amendments thereto as may be from time to time be furnished or approved in writing by the Employer.

“Deputy Conservator” shall mean the Deputy Conservator of Cochin Port Authority and includes any officer who is authorized on his behalf for the purpose of this contract.

“Tender” means the offer of the contractor along with all other relevant documents as referred to in the contract.

“MES” means Marine Engineering Superintendent, CoPA

10.2. Clause 13 INSURANCE is deleted.

10.3. Clause 14 ‘Site Investigation Reports’ is deleted.

10.4. Clause 18 Approval by the Engineer or his nominee is deleted

10.5. Clause 20 ‘Discoveries’ is deleted.

**Cochin Port Authority**  
**TENDER No.MD/PMW/ GHDNS GRAB REPAIRS /2022-24**

10.6. Clause 21, Possession of the Site is substituted by 'Take over of each Grab by Contractor for repairs'.

- (i) The Contractor shall take over each Grab for repairs from CoPA after giving proper receipt duly signed by the authorised representative of the contractor.

11. Clause 25 Settlement of Disputes and Arbitration is modified as follows:

11.1 Except where otherwise provided in the contract all questions and disputes relating to the meaning of the specifications, design, drawings and instructions here-in before mentioned and as to the quality of workmanship or materials used on the work or as to any other question, claim, right, matter or thing whatsoever in any way arising out of or relating to the contract, designs, drawings, specifications, estimates, instructions, orders or these conditions or otherwise concerning the works or the execution or failure to execute the same whether arising during the progress of the work or after the cancellation, termination, completion or abandonment thereof shall be dealt with as mentioned hereinafter:-

11.2. If the Contractor considers any work demanded of him to be outside the requirements of the contract, or disputes any drawings, record or decision given in writing by the Engineer-in-charge on any matter in connection with or arising out of the contract or carrying out of the work, to be unacceptable, he shall promptly within 15 days request the Engineer in writing for written instruction or decision. Thereupon, the Engineer shall give his written instructions or decision within a period of one month from the receipt of the Contractor's letter. If the Engineer fails to give his instructions or decision in writing within the aforesaid period or if the Contractor is dissatisfied with the instructions or decision of the Engineer, the Contractor may, within 15 days of the receipt of Engineer's decision, appeal to the Chairman, CoPA who shall afford an opportunity to the Contractor to be heard, if the latter so desires, and to offer evidence in support of his appeal. The Chairman shall give his decision within 30 days of receipt of Contractor's appeal.

Clause 26 Computerised Measurement Book is deleted.

12. Part B.TIME CONTROL, Clause 27. Program, & Clause 28 Revised program are deleted.”

12.1. Clause 31- Management meetings is deleted.

13. C. QUALITY CONTROL

The following sub-clause is added as “34.2” under Clause 34, Identify Defects:

All the equipment, components, accessories etc. used if any for repairs shall be brand new and readily available in open market. All items offered shall be as per approved quality The Contractor shall execute in the best and most workmen like manner all works according to the true intent and meaning of the specifications of the contract and complete the same to the entire satisfaction of the CoPA.

D. COST CONTROL

Clause 38- Changes in quantities is deleted

Clause 40- Payments for variations is deleted

Clause 41- Cash flow forecast is deleted

Clause 42- Payments certificates is deleted

14. Clause **43 Payments is modified as follows:-**

**Cochin Port Authority**  
**TENDER No.MD/PMW/ GHDNS GRAB REPAIRS /2022-24**

14.1. The contractor shall raise GST invoice of each Grab against individual work order issued, upon satisfactory completion of work and delivery of Grab at CoPA premises. 100% of total cost of repair of each Grab as per the invoice, duly certified by MES or his representatives, will be paid. While effecting payment, applicable LD if any will be deducted from each invoice as per the contract condition. Income tax and GST TDS at the prevailing rate will be deducted from each bill. In order to release payments, the contractor has to execute the Agreement and furnish Performance Security as per the contractual requirements.

15. 43.2 General:-

- (i) GST will be paid extra as applicable.
- (ii) **Income Tax Deduction:** Deduction of Income Tax shall be made from any amount payable to the Contractor as per the relevant provisions of the Income Tax Act.
- (iii) **TDS under GST Law:** As per GST Notification No. 50/2018 dated 13.09.2018, TDS @ 2% will be deducted from any amount payable to the Contractor, where the total value of contract is more than Rs. 2.5 lakhs.
- (iv) Any penal interest, penalty or fine payable / paid by the contractor to the Tax Authorities on the Taxes and Duties shall not be paid / reimbursed by the CoPA under any circumstances.
- (v) All payments to the Contractors will be released through RTGS / e-payments. The contractor is therefore required to furnish the relevant bank information for the same along with their invoices.
- (vi) All payments to the Contractor under the contract shall unless otherwise stated elsewhere be made to the Contractor in Indian currency through e- payments through designated Bank.
- (vii) Cochin Port Authority's Lien: Cochin Port Authority shall have lien on all or any moneys that may become due and payable to the contractor under these presents or in respect of any debt or sums that may become due and payable by Cochin Port to the contractor either alone or jointly with another or others and either under this or under any other contact or transaction of any nature whatsoever between the Cochin Port and the Contractor.

15.1. Clause 44 : Compensation Events is deleted:-

15.2. Clause 45- Rate for items to be inclusive of taxes is modified as follows: The rate quoted by the contractor shall be inclusive of labour, materials and consumables required for repairs of the grab and all charges what so ever excluding GST.

15.3. Clause 47 : Price adjustment is deleted:-

15.4. Clause 48 : Retention is deleted:-

16. **Clause 49 Liquidated Damages:-**

16.1. Sub clause 49A and 49A(1) are modified as follows:-

49A: The completion period fixed for each Grabs shall be Two Months from the date of taking over the Grab From CoPA by the contractor. All the line items of works as per the

**Cochin Port Authority**  
**TENDER No.MD/PMW/ GHDNS GRAB REPAIRS /2022-24**

work order issued for each Grabs shall be completed within a period Two Months from the date of taking over the Grab From CoPA by the contractor, failing which LD shall be levied. In case of delay in completion of works of a particular Grab, as per work order issued, Liquidated Damages (LD) shall be levied at the rate of Half percentage of the contract price per week of delay, subject to a maximum of 10 % of the contract price. For the purpose of calculating LD for a particular Grab, the contract price shall be the total cost of repair of the particular Grab as per the invoice raised by the contractor based on the actual quantum of work done duly certified by MES or his representatives. While releasing payment for each Grab, the applicable LD will be deducted.

49A(1): The Employer, if satisfied, that the works can be completed by the contractor within a reasonable time after the specified time for completion, may allow further extension of time at its discretion with or without levy of LD. In the event of extension granted being with LD, the employer will be entitled without prejudice to any other right or remedy available in that behalf, to recover from the contractor as agreed damages equivalent to half percent of the contract value of the works for each week or part of the week subject to a maximum of 10 % of the contract price as stated in sub clause 49A above.

17. Sub Clause 49B Reduction of LD is deleted
18. Clause 50 Nominated sub contractors is deleted
19. Clause 51 Advance payment is deleted
20. Clause **52- Securities :**
21. Sub Clause 52.1 is deleted
22. Clause 52.2 of GCC related to the security deposit stands modified to the extend detailed below:

(i). In all cases, the performance grantee retained till end of defect liability period shall be 10% of the total estimated contract value excluding GST for the repairs of anticipated 24 nos Grabs as per the rates quoted by the successful bidder and as indicated in the LAO/Work order. The security deposit will be retained as security for the due and proper fulfilment of the contract and will not carry any interest. Such deposit shall be forfeited on failure to perform or non full filament by the contractor of the terms and conditions of the contract.

Clause 53- Removal of craft or plant which has sunk is deleted

23. **Section E, FINISHING THE CONTRACT:-**

24. Clause 55- Completion is deleted
25. Clause 56- Taking over is deleted
26. Clause 57-Final account is deleted
27. Clause 58- Submission of as built drawings is deleted
28. **Sub-clause 59.5 is modified as follows:-**

1. Upon termination of the Contract either by Employer or Contractor, the Contractor is liable to safely transit and handover the Grabs which are remaining at contractors repair yard to Cochin Port premises at his own risk.
2. If the Contract is terminated at Employer's convenience or because of a fundamental breach of Contract by the Employer, incidental expenses in connection the transportation

**Cochin Port Authority**  
**TENDER No.MD/PMW/ GHDNS GRAB REPAIRS /2022-24**

of the Grabs (which are remaining at contractors repair yard) from the Contractor's Yard to Employer's premises will be reimbursed by the Employer to the Contractor.

3. If the Contract is terminated because of a fundamental breach of Contract by the Contractor, all expenses in connection with the transportation of the Grabs (which are remaining at contractors repair yard) from the Contractor's Yard to Employer's premises shall be borne by the Contractor and Cochin Port is entitled to encash the bank guarantee furnished towards security deposit/ performance guarantee.

29. **Section F, LOBOUR LAWS AND MISCELLANEOUS CLAUSES:-**

30. Clause 66- Insurance of works and contractors equipment is deleted
31. Clause 67- War risk insurance is deleted
32. Clause – 68- Royalties is deleted
33. Clause 69- Transport of contractors equipment or temporary works is deleted
34. Clause 77- Contractors temporary works, office etc is deleted
35. Clause 78-Water supply is deleted
36. Clause 79-Power supply is deleted
37. Clause 80- Taxes and duties is deleted
38. Clause 81 Noises and disturbance is deleted
39. Clause 85-Drawings and designs is deleted
40. Clause 87- Reports is deleted
41. Clause 88- Completion documents is deleted
42. Clause 89-Final account is deleted

**SECTION IV. SCOPE OF WORK & DRAWINGS**

The Special Conditions will supersede the general conditions of contract wherever they differ.

- 4.1. This tender is for “Rate Contract for Repairs of Grabs of COPA’s Grab Hopper Dredger Nehru Shatabdi for Two years”. The approximate numbers of Grabs to be repaired during the contact period is Twenty Four. The actual number of Grabs to be repaired may vary as per CoPA requirement. Contract covers maintenance/repairs of grabs of Cochin Port Authority’s Dredger, ‘GHD Nehru Shatabdi’. Works detailed in the price schedule comprises of various works connected with repair / reconditioning of grabs. It is not necessary that all the works listed in the schedule of work are to be carried out on all grabs taken up for repairs. Drawings and parts of grab are detailed bellow
- 4.2. As and when repair/renewal work arises, verbal/e-mail intimation will be given to the contractor. The work should be commenced immediately on receipt of such intimation of CoPA. Firm work order will be issued subsequently. As and when defects are observed on any of the grabs, they will be placed at a quay (berth) where the dredger GHD Nehru Shatabdi can be berthed.
- 4.3. **The repair/renewal works of each grabs shall be done at contractor’s Repair Yard. After receiving verbal/email intimation as above for each grab, the contractor shall transport the grab to his site for repairs by contractor’s vehicle at his own risk and cost.**
- 4.4. After dismantling the defective grab by the contractor at his site, MES or his representative along with **Engineer-in-charge will survey and list out details of work. Based on this, individual work order will be placed for each grab, line item wise as per the price schedule.**
- 4.5. **Based on the above individual work order, the contractor shall carryout the repairs.**
- 4.6. **After the completion of repairs, the contractor shall transport the grab to CoPA premises by contractor’s vehicle at his own risk and cost.**
- 4.7. CoPA will provide **cranes/lifting equipments at Ports account**for loading/unloading the grab/ its components into/from the contractors’ vehicle at CoPA premises. Any minor work which is required to be carried out during commissioning/operation of grabs will be permitted to undertake in CoPA premises.
- 4.8. **All labour, materials and consumables required for repairs of the grab shall be in the scope of the contractor and cost of same also should be included in the quoted rate.**
- 4.9. The contractor should employ sufficient number of working groups consisting of skilled workers and supervisors simultaneously to carry out the work. Supervisors must be qualified, experienced and must have capability and responsibility to interact with Port Officers
- 4.10. Work completion period for each grab will be 2 months (maximum) from the date of handing over of grab to the contractor. However, the contractor shall make all efforts to complete the work in minimum time. On justifiable circumstance, additional time for completion of the work will be granted by EIC up on request of the contractor.
- 4.11. **The contractor should give a Guarantee of Three months for each repaired grab from the date of fitting the grab in the vessel for operation after repairs, for workmanship /materials used for repairs.**

**Cochin Port Authority**  
**TENDER No.MD/PMW/ GHDNS GRAB REPAIRS /2022-24**

- 4.12. Any defect / damage found in the attended work during initial operation of grab after repairs, due to poor workmanship / material used by the contractor, should be rectified by the contractor at his sole risk and cost and to the entire satisfaction of the Engineer-in-Charge within the guarantee period of three months.
- 4.13. The contractor will be responsible for the safe custody of Grabs taken for repairs from Port Authority and till delivery of the Grab after repairs to CoPA premises. Any expenditure due to loss or damage to Grabs and also to any property of the CoPA caused on account of this work will be realised from the contractor.
- 4.14. **Schedule of works :**  
All the materials / spares required for repairs shall be under the scope of the contractor. The schedule of works including the components/materials required for repairs are furnished below:

**Schedule I**

Sl. No.	Part No.	Details of Work
1	1.2	Renewal of Outside Bush out of MS
2	1.7	Renewal of 6.5 ton D Shackle
3	1.8	Renewal of Clamping Bush out of EN 8 Steel 60x50x125
4	1.9	Renewal of Bearing Bush of D Shackle out of EN 8 Steel
5	2.3	Renewal of Ring out of EN 8 Steel
6	2.4	Renewal of Pin of Suspension out of EN 8 Steel
7	2.5	Renewal of Lubricating Nipple 1/8"
8	2.6	Renewal of Expansion Plug 1/8"
9	2.8	Renewal of MS Washer M45
10	2.9	Renewal of MS Nut M45
11	3.2	Repairs of Rope Guide Pot
12	3.3	Renewal of Adjusting Screw with Hexagon Socket M16x25
13	4.1	Renewal of Wire Rope pulley
14	4.2	Renewal of Cylinder Roller Bearing with Nylon Bush
15	4.4.1	Repairs of Pulley Shaft out of EN 8 Steel
16	4.4.2	Renewal of Pulley Shaft out of EN 8 Steel
17	4.5	Renewal of Ring out of MS
18	4.6	Renewal of Ring out of MS
19	4.7	Renewal of MS Bolt M12x130
20	4.8	Renewal of Nyloc Nut M12
21	4.9	Renewal of Lubricating Nipple 1/8"
22	4.1	Renewal of Expansion Plug
23	4.20.1	Repairs of Arm Shaft out of EN 8 Steel

**Cochin Port Authority**  
**TENDER No.MD/PMW/ GHDNS GRAB REPAIRS /2022-24**

24	4.20.2	Renewal of Arm Shaft out of EN 8 Steel
25	4.21	Renewal of Ring out of MS
26	4.22	Renewal of Ring out of MS
27	4.23	Renewal of MS Bolt M12x120
28	4.25	Renewal of Ring out of Nylon
29	4.26	Renewal of Expansion Plug 1/8"
30	5.2	Renewal of Cylinder Roller Bearing with Nylon Bush
31	5.4.1	Repairs of Pulley Shaft out of EN 8 Steel
32	5.4.2	Renewal of Pulley Shaft out of EN 8 Steel
33	5.5	Renewal of Expansion Plug
34	5.6	Renewal of MS Bolt M12x130
35	5.7	Renewal of Nyloc Nut M12
36	5.8	Renewal of MS Ring
37	5.9	Renewal of MS Ring
38	5.1	Renewal of MS Ring
39	5.11	Renewal of MS Key of Shaft 30x15x90
40	5.12	Renewal of MS Square
41	5.13	Renewal of MS Bolt M10x30
42	5.14	Renewal of Spring Washer M10
43	5.15	Renewal of Lubricating Nipple 1/8"
44	5.16	Renewal of Expansion Plug 1/8"
45	5.21.1	Repairs of Turning Point Shaft out of EN 8 Steel
46	5.21.2	Renewal of Turning Point Shaft out of EN 8 Steel
47	6.1	Repairs of Bearing House by boring and bushing EN 8 Bush
48	6.2	Renewal of Spherical Bearing with EN 8 steel bush
49	6.6	Repairs of Bearing House of Arm by boring and bushing EN 8 Bush
50	7.1.1	Repairs of Turning Point Shaft
51	7.1.2	Renewal of Turning Point Shaft
52	7.2	Renewal of Lubricating Nipple 1/8"
53	7.3	Renewal of Expansion Plug 1/8"
54	7.4	Renewal of Expansion Plug
55	7.7	Renewal of MS Key of Shaft 30x15x90
56	7.8	Renewal of MS Bolt M10x30
57	7.9	Renewal of Spring Washer M10
58	7.18	Renewal of Outside Bush out of MS
59	7.19	Renewal of Bearing Bush out of Bronze
60		Charges for to and fro transporting / handling of grab
61		Charges for general cleaning and arranging for inspection of grab

**Cochin Port Authority**  
**TENDER No.MD/PMW/ GHDNS GRAB REPAIRS /2022-24**

**Schedule II**

**Steel renewal Works**

Sl. No.	Part No.	Details of Work
1	1.1	Repairs of Main Plate out of MS
2	1.3	Repairs of Upper Plate out of MS
3	1.4	Repairs of Plate out of MS
4	1.5	Repairs of Protection Plate out of MS
5	1.6	Repairs of Protection Plate out of MS
6	2.1	Repairs of Suspension Plate out of MS
7	2.2	Repairs of Protection Plate out of MS
8	2.7	Repairs of Locking Plate out of MS
9	2.10	Repairs of Locking Plate out of MS
10	2.11	Repairs of Strip out of MS
11	4.11	Repairs of Outside Pulley Plate out of MS
12	4.12	Repairs of Between Pulley Plate out of MS
13	4.13	Repairs of Back Plate out of MS
14	4.14	Repairs of Intermediate Plate out of MS
15	4.15	Repairs of Plate out of MS
16	4.16	Repairs of Large Cam Plate out of MS
17	4.17	Repairs of Small Cam Plate out of MS
18	4.18	Repairs of Ear Plate out of MS
19	4.19	Repairs of Strip out of MS
20	4.24	Repairs of Upper Plate out of MS
21	4.27	Repairs of Wire Rope Guard out of 20 mm dia. MS Rod
22	5.17	Repairs of Outside Pulley Plate
23	5.18	Repairs of Between Pulley Plate
24	5.19	Renewal of MS Strip
25	5.20	Renewal of MS Strip
26	5.22	Repairs of Under Block Ear Plate out of MS
27	5.23	Repairs of Under Block Ear Plate out of MS
28	5.24	Repairs of Shore Plate out of MS
29	5.25	Repairs of Intermediate Plate out of MS
30	5.26	Repairs of Upper Plate out of MS
31	5.27	Repairs for Plate out of MS
32	5.28	Repairs for Plate out of MS
33	5.29	Repairs for Strengthening Plate out of MS
34	5.30	Repairs for Strengthening Plate out of MS
35	5.31	Repairs of Cut off Socket out of MS
36	5.32	Repairs of MS Wedge
37	5.33	Repairs of Wire Rope Guard out of 20 mm dia. MS Rod
38	6.7	Repairs of Shore Plate out of MS
39	6.8	Repairs of Side Knife out of MS
40	6.9	Repairs of Strengthening Plate out of MS

**Cochin Port Authority**  
**TENDER No.MD/PMW/ GHDNS GRAB REPAIRS /2022-24**

41	6.10	Repair of Under Knife out of MS
42	6.11	Repairs of Strip out of MS
43	6.12	Repairs of Strengthening Plate out of MS
44	6.13	Repairs of Scoop Plate out of MS
45	6.14	Repairs of Tubular Bridge out of MS
46	6.15	Repairs of Back Strip out of MS
47	6.16	Repairs of Base Plate out of MS
48	6.17	Repairs of Stop Plate out of MS
49	6.18	Renewal of MS Round out of 20mm MS rod
50	7.5	Repairs of Ear Plate out of MS
51	7.6	Repairs of Ear Plate out of MS
52	7.10	Repairs of MS Square
53	7.11	Repairs of MS Base Plate
54	7.12	Repairs of Strengthening Plate out of MS
55	7.13	Repairs of MS Strip
56	7.14	Repairs of Box Profile of Mobile Arm out of MS
57	7.15	Repairs of Box Profile of Fixed Arm out of MS
58	7.16	Repairs of Head Connecting Plate out of MS
59	7.17	Repairs of Number Plate out of MS
60	7.20	Repairs of Strengthening Plate out of MS
61	7.21	Repairs of Name Plate out of MS
62	7.22	Repairs of Strengthening Plate out of MS
63	7.23	Repairs of Bobcat Plate out of MS

**Signature of the tenderer with date and seal**

**Drawings:**

**The drawings and other details of components of Grabs are furnished below:**

Annexure I. Drawings and Part numbers  
**DRG. NO. 1 : SUSPENSION**

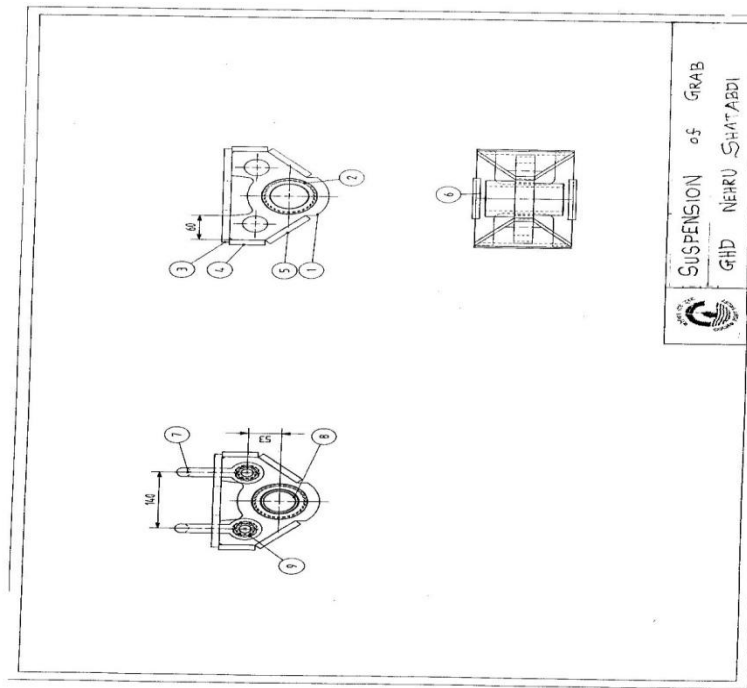

<b>Part. No.</b>	<b>Description of Item</b>	<b>Quantity in Nos.</b>
1.1	Main Plate	1
1.2	Outside Bush	1
1.3	Upper Plate	1
1.4	Plate	2
1.5	Protection Plate	2
1.6	Protection Plate	2
1.7	D Shackle	4
1.8	Clamping Bush	1
1.9	Bearing Bush; D Shackle	2

**DRG. NO. 2 : SUSPENSION SET**

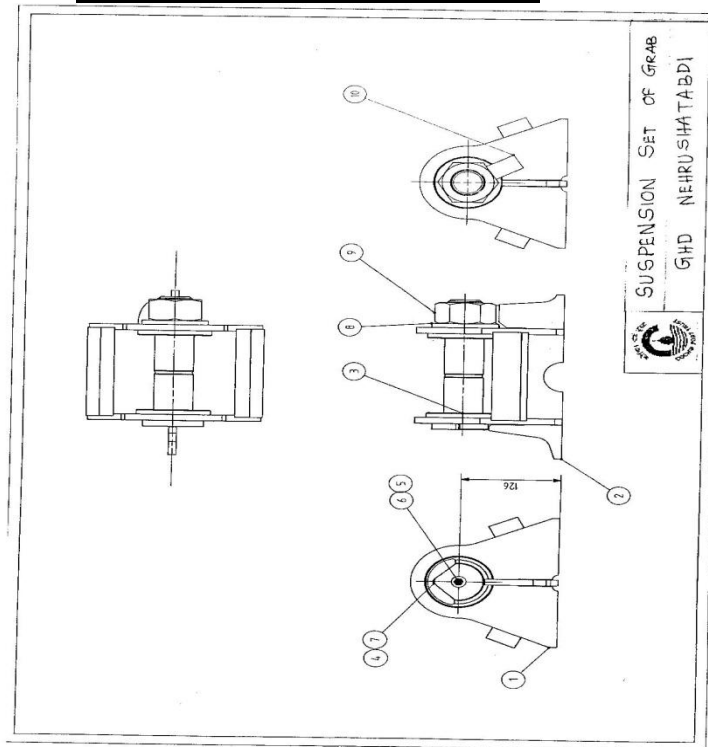

<b>Part. No.</b>	<b>Description of Item</b>	<b>Quantity in Nos.</b>
2.1	Plate; Suspension	2
2.2	Protection Plate	1
2.3	Ring	2
2.4	Pin; Suspension	1
2.5	Lubricating Nipple	1
2.6	Expansion Plug	1
2.7	Locking Plate	1
2.8	Steel Washer	1
2.9	Nut	1
2.10	Locking Plate	1
2.11	Strip	2

**DRG. NO. 3 : ROPE GUIDING POT**

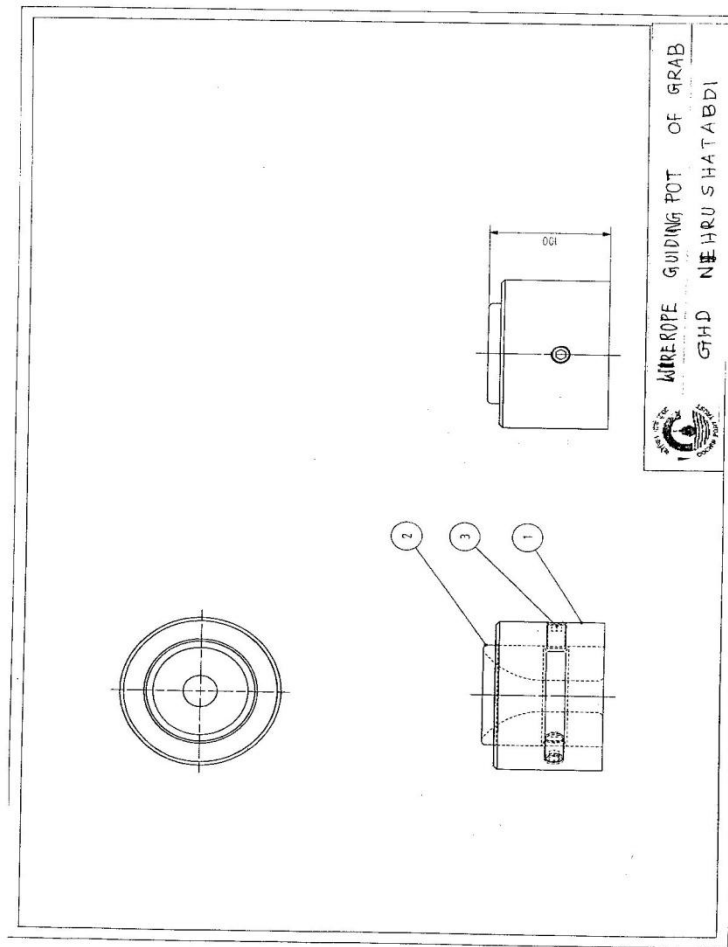

<b>Part. No.</b>	<b>Description of Item</b>	<b>Quantity in Nos.</b>
3.1	Outside Bush	1
3.2	Rope Guide Pot	1
3.3	Adjusting Screw with Hexagon Socket	2

**DRG. NO. 4 : HEAD**

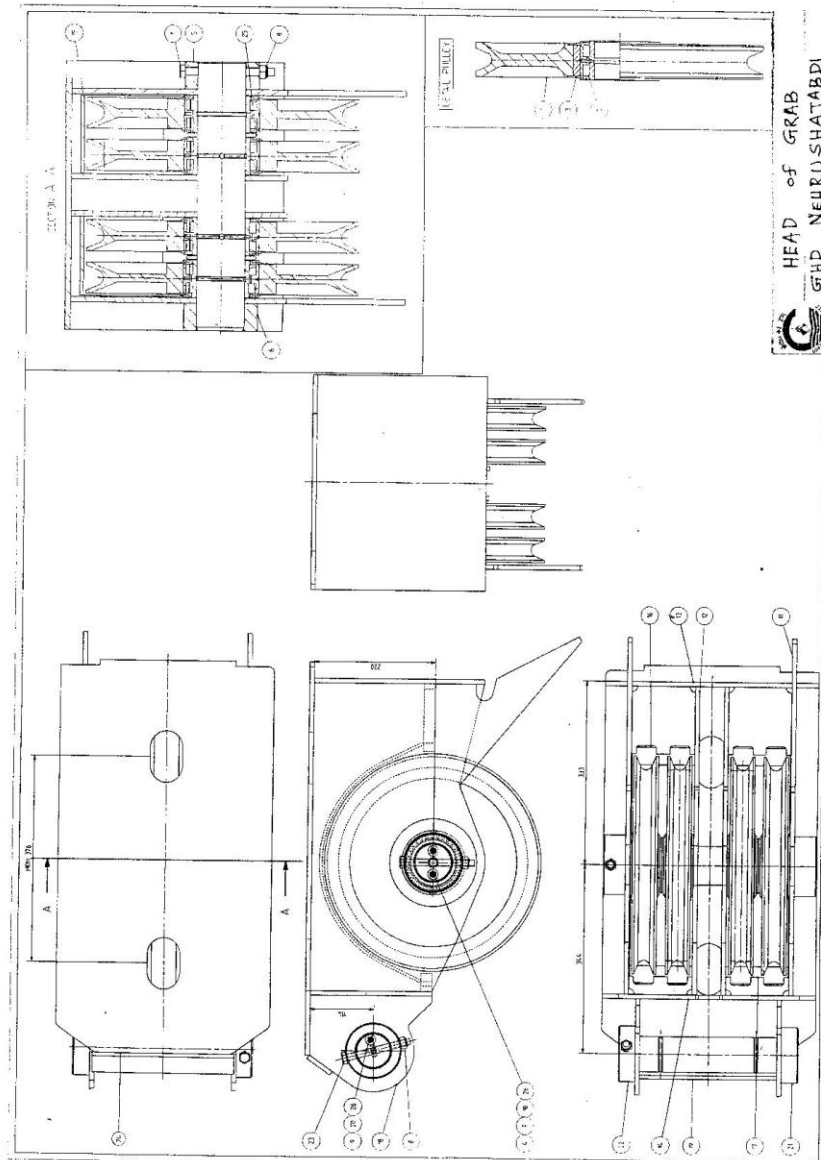

HEAD of GRAB  
GHD NEHRUSHATABDI

**Cochin Port Authority**  
**TENDER No.MD/PMW/ GHDNS GRAB REPAIRS /2022-24**

<b>Part. No.</b>	<b>Description of Item</b>	<b>Quantity in Nos.</b>
4.1	Wire Rope Pulley	4
4.2	Cylinder Roller Bearing	4
4.3	Locking Ring	8
4.4	Shaft; Pulley	1
4.5	Ring	1
4.6	Ring	1
4.7	Bolt	1
4.8	Nut; Nyloc	2
4.9	Lubricating Nipple	6
4.10	Expansion Plug	1
4.11	Pulley Plate; Outside	2
4.12	Pulley Plate; Between	2
4.13	Back Plate	1
4.14	Intermediate Plate	1
4.15	Plate	2
4.16	Cam Plate; Large	2
4.17	Cam Plate; Small	2
4.18	Ear Plate	2
4.19	Strip	1
4.20	Shaft; Arm	1
4.21	Ring	1
4.22	Ring	1
4.23	Bolt	1
4.24	Upper Plate	1
4.25	Ring	2
4.26	Expansion Plug	6

**DRG. NO. 5 : UNDER BLOCK**

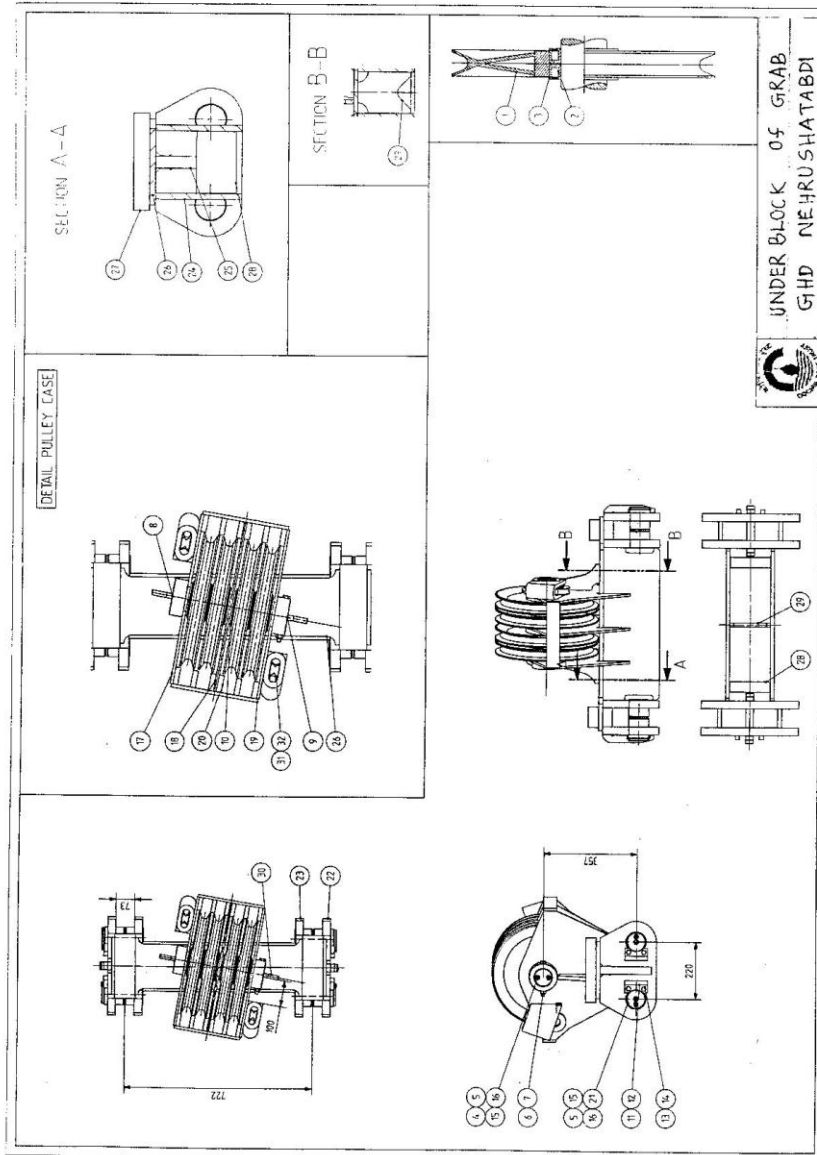

**Cochin Port Authority**  
**TENDER No.MD/PMW/ GHDNS GRAB REPAIRS /2022-24**

<b>Part. No.</b>	<b>Description of Item</b>	<b>Quantity in Nos.</b>
5.1	Wire Rope Pulley	4
5.2	Cylinder Roller Bearing	4
5.3	Locking Ring	8
5.4	Shaft; Pulley	1
5.5	Expansion Plug	5
5.6	Bolt	1
5.7	Nut; Nyloc	1
5.8	Ring	1
5.9	Ring	1
5.10	Ring	1
5.11	Key; Shaft	4
5.12	Square	4
5.13	Bolt	8
5.14	Spring Washer	8
5.15	Lubricating Nipple	8
5.16	Expansion Plug	8
5.17	Pulley Plate; Outside	2
5.18	Pulley Plate; Between	1
5.19	Strip	2
5.20	Strip	12
5.21	Shaft; Turning Point	4
5.22	Ear Plate; Under Block	2
5.23	Ear Plate; Under Block	2
5.24	Shore Plate	2
5.25	Intermediate Plate	2
5.26	Upper Plate	1
5.27	Plate	2
5.28	Plate	2
5.29	Strengthening Plate	1
5.30	Strengthening Plate	2
5.31	Socket; Cut Off	2
5.32	Wedge	2

**DRG. NO. 6 : SCOOP**

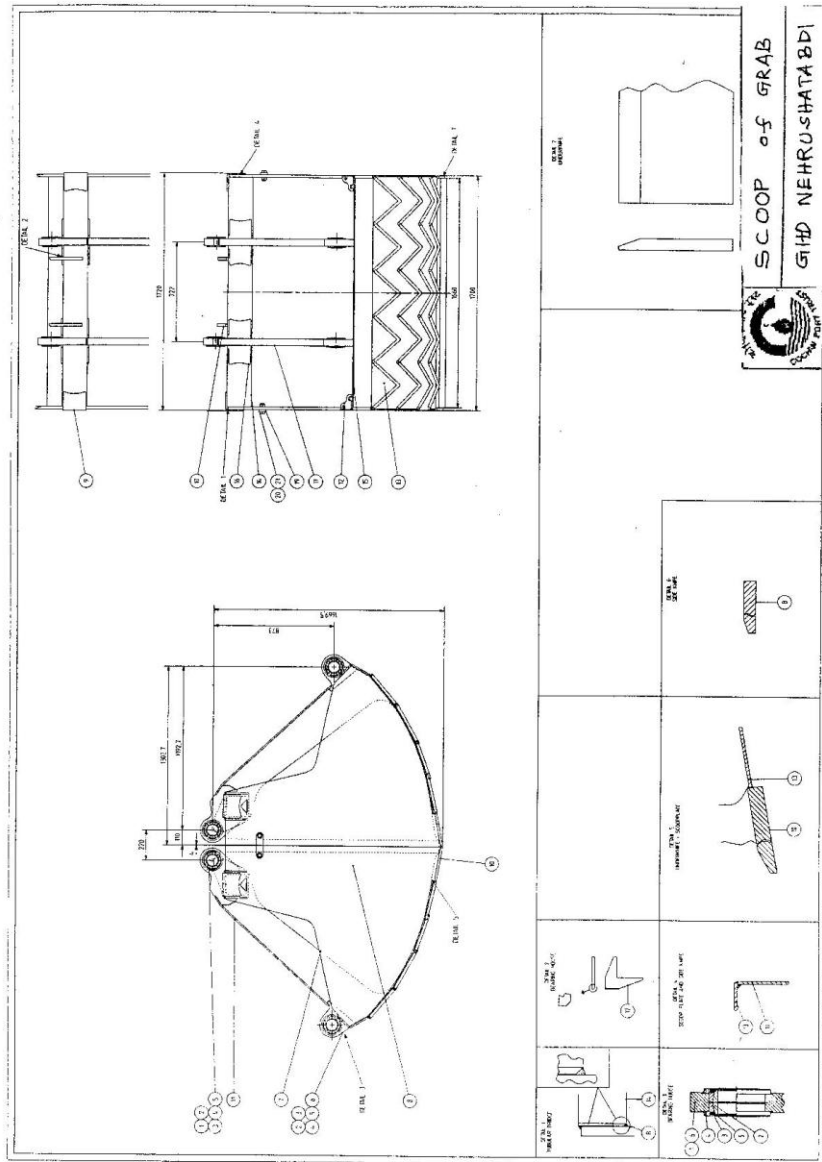

SCOP OF GRAB  
 GHD NEHRUSHATABDI



**Cochin Port Authority**  
**TENDER No.MD/PMW/ GHDNS GRAB REPAIRS /2022-24**

<b>Part. No.</b>	<b>Description of Item</b>	<b>Quantity in Nos.</b>
6.1	Bearing House	8
6.2	Spherical Bearing	8
6.3	CD Sealing Ring	16
6.4	Locking ring	16
6.5	Ring	16
6.6	Bearing House; Arm	4
6.7	Shore Plate	4
6.8	Side Knife	4
6.9	Strengthening Plate	4
6.10	Under Knife	2
6.11	Strip	4
6.12	Strengthening Plate	4
6.13	Scoop Plate	2
6.14	Tubular Bridge	2
6.15	Strip; Back Strip	2
6.16	Base Plate	8
6.17	Stop Plate	4
6.18	Round	80
6.19	Transport Plate	2
6.20	Bolt	4
6.21	Nut	4

**DRG. NO. 7 : ARM**

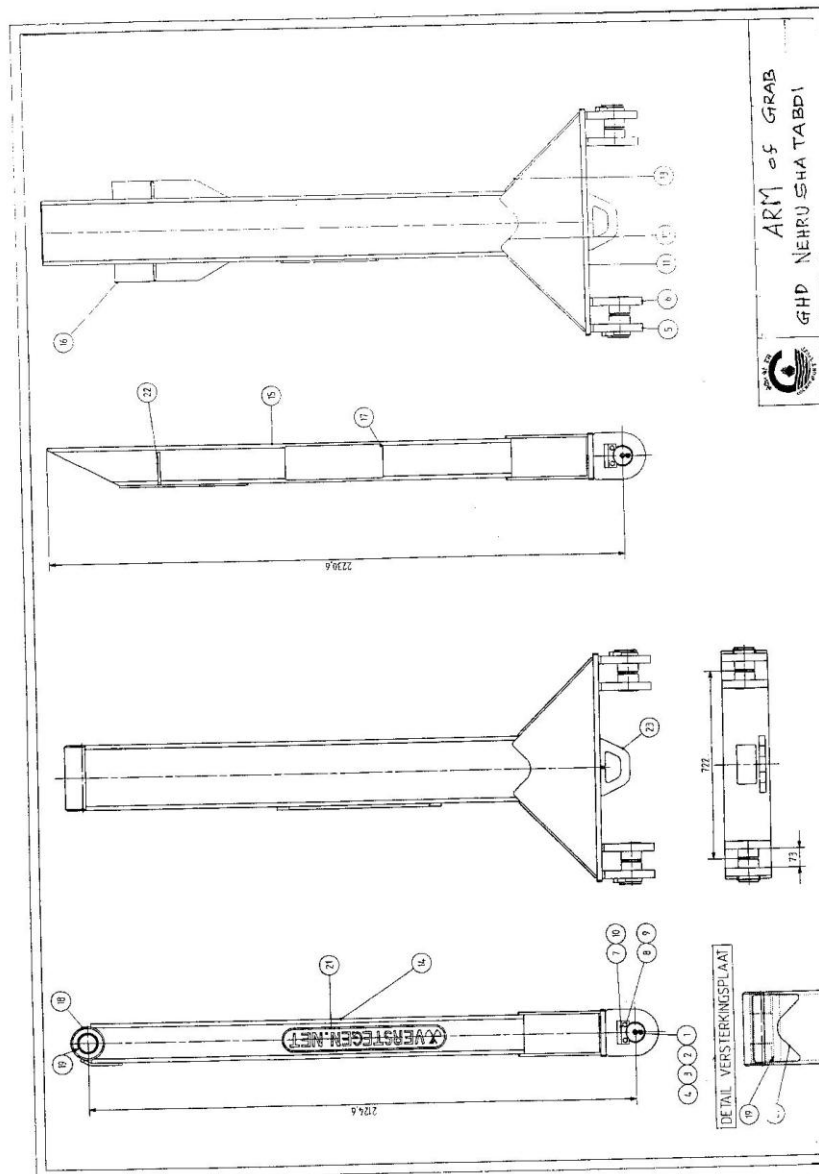

GHD NEHRU SHA TABDI  
ARM of GRAB

**Cochin Port Authority**  
**TENDER No.MD/PMW/ GHDNS GRAB REPAIRS /2022-24**

<b>Part. No.</b>	<b>Description of Item</b>	<b>Quantity in Nos.</b>
7.1	Shaft; Turning Point	4
7.2	Lubricating Nipple	4
7.3	Expansion Plug	4
7.4	Expansion Plug	4
7.5	Ear Plate; Outside / Arm / Inside	12
7.6	Ear Plate; Outside / Arm / Inside	12
7.7	Key; Shaft	4
7.8	Bolt	8
7.9	Spring Washer	8
7.10	Square	4
7.11	Base Plate	2
7.12	Strengthening Plate	4
7.13	Strip	4
7.14	Box Profile; Arm Mobile	1
7.15	Box Profile; Arm Fixed	1
7.16	Head Connecting Plate	1
7.17	Number Plate	1
7.18	Outside Bush	1
7.19	Bearing Bush	2
7.20	Strengthening Plate	1
7.21	Name Plate	1
7.22	Strengthening Plate	2
7.23	Bobcat Plate	2

**V- BILL OF QUANTITIES (Price Schedule I&II)**

(Attached separately)